

# SERVICE MANUAL

**marantz**

**model 4400**

*Stereo 2 + Quadradial 4 Receiver*

**TABLE OF CONTENTS**

SECTION	PAGE
Introduction .....	1
Service Notes .....	1
AM Tuner .....	1
FM Tuner .....	2
Phono and Pre-Amplifier .....	5
Dolby Unit .....	6
400Hz Tone .....	7
Dolby NR Switch .....	7
Record Level (L) (R) .....	8
Play Cal. (L) (R) .....	8
Dolby FM Preset Level Controls .....	8
400Hz Tone Switch .....	8
FM De-Emphasis Switch .....	8
Hi-Low Filter Amplifier .....	8
Power Amplifier .....	8
BTL (Balanced Transformer-less) Connection .....	9
Power Supply Circuit .....	9
Audio Trouble Analysis .....	9
Scope Display Circuit .....	9
Scope Circuit Description .....	10
Trouble Shooting of Oscilloscope Circuit .....	11
Test Equipment Required for Servicing .....	12
Scope Display Alignment .....	12
AM Tuning Display Alignment .....	13
FM Tuning Display Alignment .....	13
AM Alignment Procedure .....	13
FM Alignment Procedure .....	13
Audio Adjustment .....	15
Automatic Voltage Regulator Adjustment .....	15
Dolby Alignment Procedures .....	15
Alignment Procedures of Dolby FM Preset Level Controls .....	16
Explanation of the Dolby Processing Chart .....	17
Parts List .....	32 ~ 51
Technical Specifications .....	52, 53

**LIST OF ILLUSTRATIONS**

FIGURE	PAGE
1. Block Diagram of the HA1156 .....	4
2. Dial Stringing .....	14
3. Dolby Alignment Implement Simplified Schematic .....	16
4. Front Panel Adjustment and Component Locations .....	19
5. Main Chassis Component Locations (Bottom View) .....	19
6. Rear Panel Adjustment and Component Locations .....	20
7. Main Chassis Component Locations (Top View) .....	20
8. FM Front End Assembly P100 Component Locations .....	21
9. AM Tuner Assembly P150 Component Locations .....	21
10. FM IF Amplifier Assembly P200 Component Locations .....	21

11. MPX Stereo Decoder, Noise and DC Amplifier Assembly P300 Component Locations .....	22
12. Phono Amplifier Assembly P400 Component Locations .....	22
13. Vari-Matrix Assembly P500 Component Locations .....	23
14. Dolby Unit Assembly P600 Component Locations .....	23
15. Power Amplifier Assembly P700 Component Locations and Schematic Diagram .....	24
16. Power Supply Assembly P800 Component Locations .....	25
17. Scope Display Amplifier Assembly P900 Component Locations .....	25
18. FM Cal. Assembly PC01 Component Locations .....	25
19. Tone Amplifier Assembly PD01 Component Locations .....	26
20. Buffer and Pre-Amplifier Assembly PE01 Component Locations .....	26
21. Tone Control Unit and Diode Matrix Assembly PF01 Component Locations .....	26
22. Balance Control Unit Assembly PG01 Component Locations .....	27
23. Filter Amplifier Assembly PH01 Component Locations .....	27
24. 400Hz Oscillator and Meter Driver Assembly PL01 Component Locations .....	27
25. Phase Convertor Assembly PM01 Component Locations .....	27
26. Speaker Protector Assembly PN01 Component Locations .....	28
27. Fuse Unit Assembly PP01 Component Locations .....	28
28. Switch Unit Assembly PS01 Component Locations .....	28
29. Switch Unit Assembly PT01 Component Locations .....	29
30. FM De-emphasis Assembly PU01 Component Locations .....	29
31. Dolby Terminal Assembly PV01 Component Locations .....	29
32. Headphone Assembly PW01 Component Locations .....	29
33. Meter Lamp Assembly PX01 Component Locations .....	29
34. Selector Lamps Assembly PY01 Component Locations .....	29
35. Dial Lamps Assembly PZ01 Component Locations .....	29
36. Exploded Mechanical Diagram .....	30, 31
37. Schematic Diagram .....	54

	PAGE
1. Test Equipment Required for Servicing .....	12
2. Dolby Processing Chart .....	18

**INTRODUCTION**

This service manual was prepared for use by Authorized Warranty Stations and contains service information for Marantz Model 4400 Stereo 2+Quadradiat 4 Receiver.

Servicing information and voltage data included in this manual are intended for use by the knowledgeable and experienced technician only. All instruction should be read carefully. No attempt should be made to proceed without a good understanding of the operation in the receiver.

The parts list provides information by which replacement parts may be ordered from the Marantz Company. A simple description is included for parts which can be usually be obtained through local suppliers.

**1. SERVICE NOTES**

As can be seen from the circuit diagram, the chassis of Model 4400 consists of the following module units. Each unit mounted on a printed circuit board is described within the square enclosed by a bold dotted line on the circuit diagram.

1. FM Front End	mounted on P.W. Board, P100
2. AM Tuner	mounted on P.W. Board, P150
3. FM IF Amplifier	mounted on P.W. Board, P200
4. MPX Stereo Decoder, Noise and DC Amplifier	mounted on P.W. Board, P300
5. Phono Amplifier	mounted on P.W. Board, P400
6. Vari-Matrix	mounted on P.W. Board, P500
7. Dolby Unit	mounted on P.W. Board, P600
8. Power Amplifier	mounted on P.W. Board, P700
9. Power Supply	mounted on P.W. Board, P800
10. Scope Amplifier	mounted on P.W. Board, P900
11. FM CAL	mounted on P.W. Board, PC01
12. Tone Amplifier	mounted on P.W. Board, PD01
13. Buffer and Pre-Amplifier	mounted on P.W. Board, PE01
14. Tone Control and Diode Matrix Unit	mounted on P.W. Board, PF01
15. Balance Control Unit	mounted on P.W. Board, PG01
16. Filter Amplifier	mounted on P.W. Board, PH01
17. 400Hz Oscillator and Meter Driver	mounted on P.W. Board, PL01
18. Phase Convertor	mounted on P.W. Board, PM01
19. Speaker Protector	mounted on P.W. Board, PN01
20. Fuse Unit	mounted on P.W. Board, PP01
21. Switch Unit	mounted on P.W. Board, PS01
22. Switch Unit	mounted on P.W. Board, PT01
23. FM De-emphasis	mounted on P.W. Board, PU01
24. Dolby Terminal	mounted on P.W. Board, PV01
25. Head Phones	mounted on P.W. Board, PW01
26. Meter Lamp	mounted on P.W. Board, PX01
27. Selector Lamps	mounted on P.W. Board, PY01
28. Dial Lamps	mounted on P.W. Board, PZ01

**2. AM TUNER**

The AM TUNER portion of the 4400 is composed of one IC circuit (including RF amplifier, local oscillator, mixer, IF amplifier, detector, and a signal strength indicator amplifier) and one transistor amplifier to amplify the detected audio signals.

All components except the Tuning capacitor and ferrite bar antenna are mounted on printed circuit board P150.

The AM signals induced in a ferrite bar antenna are applied to the input of RF amplifier

(pin ①) through a capacitor of C151 and amplified to the level required for overcoming the conversion noises, thus giving good S/N performance. The tuned circuits inserted in both output and input circuit of RF amplifier assure very high image and spurious rejection performance.

Thus amplified and selected AM signals are then applied to one input of Mixer section (pin ⑥) through a coupling capacitor C158, while the local oscillator voltage is injected to the other input of the section (pin ⑤) through a capacitor C157. Then both the AM signal and oscillator voltage are mixed and converted into 455KHz intermediate frequency. The resulting IF signal is applied to the first IF transformer L153 consisting of one ceramic filter and two tuned circuits.

The output of L153 is led to the IF amplifier's input (pin ⑦) through a coupling capacitor C169 and amplified to sufficient level to drive the detector. The output of IF amplifier (pin ⑧) is led to the detector's input (pin ⑫) through IF filter L154. The detected audio signal derived from pin ⑪ is filtered and amplified and final audio output is obtained from the collector of H152 and applied to the TAPE MONITOR OUT jacks through the function switch.

The DC component of the detected IF signal is used as a AGC voltage to control emitter current of RF and IF amplifiers through the resistors R154 and R155. A part of the DC component is also applied to the signal strength indication amplifier incorporated in the IC. The output appears at pin ⑭ and is level adjusted by R152, indicated on the display scope H011 through vertical scope amplifier.

## 2.1 Suggestion for AM Tuner trouble shooting

Check for broken AM bar antenna, next try to tune station by rotating fly-wheel tuning knob slowly and observe the spot on the oscilloscope whether it deflects up and down or not. If the spot moves up and down as you tune past each station, no failure may exist in the stages at least preceding final IF transformer L154. Next connect a oscilloscope to the test point ③ or J157 and check for audio signals with the tuning meter deflected. If the signal strength does not deflect, check the local oscillator circuit. Normal oscillator voltage at the hot end of the oscillator tuning capacitor is about 1.5 or 3 volts, varying with tuning capacitor position. When measuring oscillator voltage use an RF VTVM; no circuit tester gives correct indication. If the local oscillator voltage is normal, check all voltage distribution in the AM circuits by using a DC VTVM and compare the measured values with those given in the schematic diagram.

## 3. FM TUNER

### 3.1 RF and IF Circuit

The FM Tuner section of the Model 4400 is divided into five functional blocks: FM Front End, IF Amplifier, Detector, Muting Control and MPX Stereo Decoding Circuit.

FM signals induced by a FM antenna are led to FM antenna coil L101 through a Balun coil. These signals are then applied to the FET RF amplifier which in turn applies its output to the next FET Mixer H102 through the triple tuned highly selective circuits. The FET Mixer converts its input signal into 10.7 MHz intermediate frequency and amplifies it at the same time. The H103 is a local oscillator and its output is injected into the source of the FET Mixer, the injection voltage is about 700 mV. The 10.7 MHz front end output is fed to the next IF amplifier unit through a coaxial cable.

The IF amplifier unit consists of seven IF amplifier stages and one AGC amplifier stage. Eight ceramic filters are also used to obtain high selectivity and four symmetrical diode limiter stages are employed for the best limiting characteristics, improved capture ratio and good AM suppression.

A part of FM Front End output is applied to the AGC amplifier H209 and its rectified output is fed back to the gate of FET RF amplifier to decrease the gain with increased signal strength.

The signals required for multipath indication are obtained from the five stages of IF amplifiers through coupling capacitors C252, C211, C214, C223 and C228 respectively and

rectified by five pair of full wave diode circuits. Thusly obtained AM components from the FM signal are appropriately mixed and applied to the vertical amplifier for multipath display.

The IF signal sufficiently amplified through each stage of IF amplifier is finally applied to the Detector Amplifier H208. The detected audio output is fed to the buffer amplifier H210 and its buffered output is fed to; (a) noise amplifier H310 through resistor R378 and capacitor C333, (b) QUADRADIAL OUTPUT Jack on the rear panel through resistor R379, (c) MPX stereo decoding IC (H321) through R301 and H301.

### 3.2 Audio Muting and Stereo Mode Auto-Selecting Circuit

The muting circuit consisting of all solid-state electrical switching has been incorporated in the Model 4400. Three inputs control the muting function. The first is related to signal strength, the second to the noise condition at the detector and the third is derived from the DC component of the detector output. These inputs are properly matrixed and gated to provide muting free from noise and transients.

The first input of DC voltage obtained by rectifying a part of IF output signal from the H205 and H206 is applied to the base of H308 and turns it on, if the IF output is greater than predetermined level (muting threshold level). When the H308 is turned on the H309 is turned off, allowing the emitter-collector resistance increasing and the collector voltage rises about 9V. The increased collector voltage increases the gate bias voltage and turns on the switching FET H301, decreasing the source-drain resistance to near zero ohm and allowing the audio signal applied to the source to flow to the pin ② of decoding IC through the source-drain path.

When the input signal is lower than predetermined level, the DC output obtained is small and can not turn on the H308, thus the H308 keeps its turn-off stage and this makes H309 turn on, decreasing the collector voltage and turning off H301. Thus no audio signals can pass through the FET. This is the fundamental principle of the muting operation but for more elaborate muting operation the second and the third inputs are necessary.

The second input is used to protect the muting operation and MPX stereo beacon lamps from misoperation due to undesirable noises. The high frequency noises included in the detected audio signals are separated by a small capacitor C333 and amplified by the noise amplifier transistor H310 and its output is rectified by the two diodes. The rectified DC output is proportional to the noise components in the audio signals.

When there are excessive noises in the audio signals such as obtained with a station incorrectly tuned in, the rectified DC output turns on the transistor H311, decreasing the emitter-collector resistance to zero. This means the collector of H309 is short-circuited to the ground, therefore the H301 is turned off and any audio signals having excessive high frequency noises can not go through the FET's source-drain path.

The transistor H317, also, turns off when transistor H309 or H311 turns on, and turns on the transistor H303 connected to pin ⑧ on the MPX decoding IC. Pin ⑧ is therefore grounded equivalently to set the IC in the monaural mode of operation. This prevent misoperation due to undesirable noises when the FM tuner is out of tuning.

The third input is obtained from the FM discriminator circuit. The DC output so called "S" curve is applied to the gate of H312 through a resistor R281 and dividing network (R361 & R362). The DC output is zero with a station correctly tuned in, but will vary from negative to positive values or vice versa when the tuning point is deviated toward either plus or minus frequency from the correct tuning frequency.

When the DC output is increased to a greater level than that of predetermined, the increased source potential of H312 makes the transistor H315 turn on (this means the collector of H309 is short-circuited to the ground), ... H301 turn off, ... H317 turn off, ... H303 turn on. This grounds pin ⑧ of the MPX stereo decoding IC, therefore the decoder is set in the monaural mode of operation and the stereo indicator lamp turns off. When the DC output is increased to the negative predetermined level, the decreased source potential turns off the H313 which in turn makes the H314 turn on (This means the collector of H309 is short-circuited to the ground).

The subsequently changes are exactly the same as that just described above.

Thus when the tuning is shifted or deviated to the certain frequencies in which undesirable noisy side-audio signals are produced, both muting and monaural/stereo Switching Transistor H303 are operated automatically and open the circuits.

With the station correctly tuned in, the bias current of the FET H312 is adjusted so that both transistor H314 and H315 are not turned on, giving no effect on the transistor H309.

### 3.3 MPX Stereo Decoding Circuit

The stereo composite signal from the buffer amplifier undergoes a phase compensation by R301 and C301, is applied through the muting switching FET H301 to the input terminal pin ②, of the MPX stereo decoding IC H321 on a PLL (Phase Locked Loop) basis, and decoded into the left and right stereo signals, which become available at pins ④ and ⑤ respectively.

These decoded left and right stereo audio signals are introduced through a low pass filter composed of L301 to L304 and C311 to C320 for elimination of undesirable residual switching signal and through a de-emphasis network consisting of R325, R326, C321 and C322, into the npn-pnp direct coupled audio amplifier, where the signals are amplified to a required level for the output from J311 and J313. From these jacks, the audio signals are led to the TAPE MONITOR OUT jacks through the function switch. Figure 1 presents an internal block diagram showing the functions of the PLL basis MPX stereo decoding IC HA1156. The input stereo composite signal, amplified by the audio amplifier, is delivered to the phase detectors PD-1 and PD-2. A part of the stereo composite signal is also applied to the stereo decoder section.

The VCO (Voltage Control Oscillator) produces a free run oscillation in the neighborhood of 76KHz with the time constant determined by a capacitor C305 and resistors R311 and R312 set on the outside of pin ⑭. The VCO output has its frequency divided into 19KHz through the two stages of the frequency divider (DIV-1 & DIV-2), and is reverted to the phase detector PD-1, which contains two input terminals designed to produce an output in proportion to the product of the two input signals. The signal applied to one of the inputs of PD-1 is the 19KHz square wave formed through frequency division of the 76KHz VCO output signal by the two stages of the frequency divider DIV-1 and DIV-2, and the 19KHz pilot signal included in the stereo composite signal as a reference signal is applied to the other input. Therefore, the output of PD-1 which has passed through the low pass filter LPF-1 provides DC output voltage in proportion to the phase variance between the two inputs. This DC output voltage is amplified by

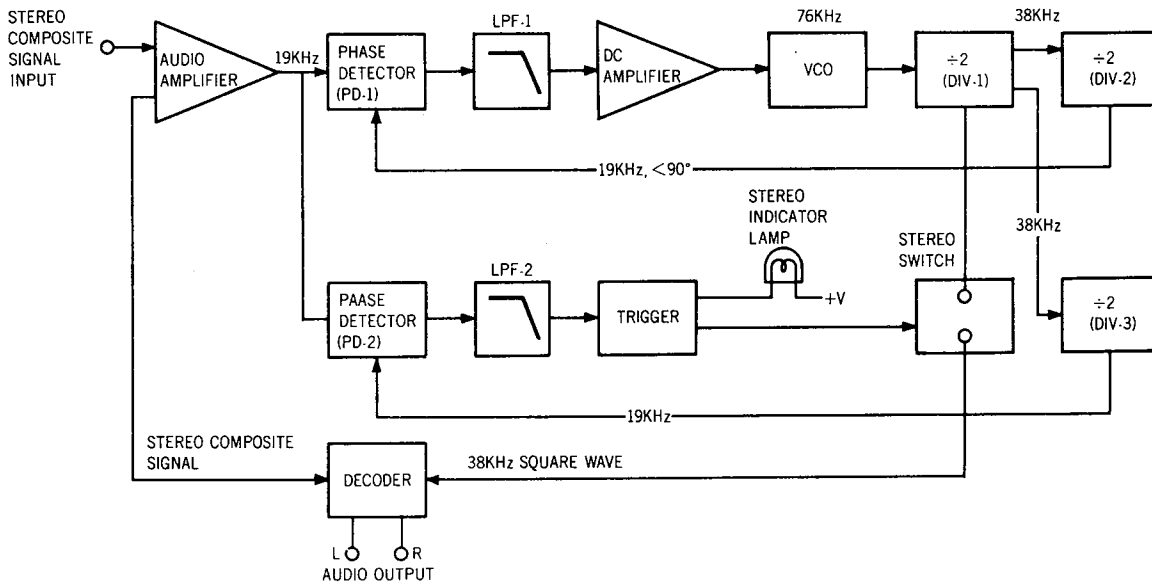

Figure 1. Block Diagram of the HA1156

the DC amplifier, and supplied to the 76KHz VCO as a control voltage. This means that the output frequency and phase of the VCO have been phase-locked to the input pilot signal. The 38KHz sub-carrier reproduced by PLL as stated above is delivered through the stereo switch to the stereo decoder section as a switching signal, thus driving the decoder section. One of the inputs of PD-2 is given the 19KHz resulting from the frequency division completed by DIV-1 and DIV-3, whereas the other input gets the 19KHz output contained in the composite signal, and the output is provided with a DC output in proportion to the amplitude of the pilot signal.

This DC output is furnished through LPF-2 to the trigger amplifier which drives the stereo indicator lamp and stereo switch. Therefore, insufficient supply of the pilot signal results in failure to light the stereo indicator and to turn on the stereo switch located in the path of the 38KHz switching signal, thereby avoiding a wrong stereo operation. H303 attached on the outside of pin ⑧ is a switching transistor for automatic monaural-stereo switchover. When the intensity of an incoming signal from an FM station is weaker than a predetermined level, this H303 is turned on and pin ⑧ is grounded, thereby developing a condition for monaural reception. For a forced monaural operation, switch the MODE switch to "MONO," and H303 comes into an "On" condition with the positive bias voltage applied to the base, and pin ⑧ is grounded, thereby establishing monaural operation. The transistor H302 connected externally to pin ⑭ is intended to stop the 76KHz oscillation of the VCO which interferes an AM signal during the reception of an AM station. When the function switch is set to "AM" position, a positive bias is charged on the base of H302, H302 is turned on, and pin ⑭ is grounded. Thus, the oscillation of the VCO is stopped, ending the interference with AM reception.

### 3.4 Suggestion for Trouble Shooting of FM Tuner

#### 3.4.1 Symptom: No FM Reception

Turn on the POWER switch.

Turn on (depress) two SCOPE DISPLAY switches "ON" and "TUNING".

First try to tune to some FM stations. (Before this tuning, make sure that the spot on the scope display is centered by following the instructions of Step 22-1 to -5 in Section 22, the "SCOPE DISPLAY ALIGNMENT".)

Rotate the fly-wheel tuning knob slowly and observe the spot on the oscilloscope whether it follows an approximately rectangular path as you tune past each station or not. If it moves as described, the tuner circuits preceding the discriminator circuit may have no failure. If not, there would be some defects in the front end or IF amplifier stages, or oscilloscope circuits. To localize the defects in the former case, check FM local oscillator circuit, using RF VTVM. The normal local oscillator voltage is one or two volts (rms) at the tuning capacitor, depending on the tuning capacitor position. If the local oscillator voltage is normal, next check all voltage distribution in the front end and IF amplifier stages and compare them with those shown in the circuit diagram.

For localizing the defects in the latter case it is one of methods to apply an audio signal to the "CD-4/AUX" INPUTS jacks (FRONT L or R) on the rear panel with the "AUDIO" SCOPE DISPLAY switch, SELECTOR switch "CD-4/AUX".

The detected audio signals can also be checked by depressing the SCOPE DISPLAY switch "AUDIO" if scope circuit operate without any defects.

#### 3.4.2 Symptom: No Stereo Separation

First check the "MODE" switch is in normal 2 CH position. Connect a FM RF signal generator output modulated by a stereo modulator to the rear FM antenna terminals, and check the stereo beacon is turned on or not. If not turned on, check for 19KHz VCO output signal (J310), using an oscilloscope and a frequency counter.

## 4. PHONO AND PRE-AMPLIFIER

Signals from the PHONO jacks are applied to the phono-amplifier mounted on P400. The amplified and RIAA equalized phono signals and signals from the tuner section, CD-4/AUX and



TAPE MONITOR IN jacks are applied to the SELECTOR switch which, in turn, leads the selected signals to the TAPE MON. switch and TAPE MONITOR OUT jacks. Applied to the other section of the TAPE MON. switch are signals from the TAPE MONITOR IN jacks. The TAPE MON. switch selects the signals from the SELECTOR switch or those from the TAPE MONITOR IN jacks and the selected signals go to the DOLBY and MODE switches. Signals are then mode processed by the MODE switch and its associated circuit and applied to the tone control amplifier through the buffer amplifier and BALANCE and VOLUME controls. The bass and treble controlled signals from the tone control amplifier pass through the hi filter before they reach the main amplifier.

#### 4.1 Mode Switch

MODE switch S002 has positions of MONO, 2 CH, DISCRETE, VARI-MATRIX, and SQ DECODER.

In the MONO position, all input signals are mixed together and delivered to all four channels.

In the 2 CH position, each pair of input signals right-front (RF) and right-rear (RR), and left-front (LF) and left-rear (LR) are mixed together. The resultant signals (RF + RR) and (LF + LR) are delivered to the pairs of RF and RR, and LF and LR channels, respectively.

In the DISCRETE position, each channel signal is separately routed to the corresponding channel.

In the VARI-MATRIX position, 2-channel stereo input signals are converted into quadraphonic signals through the vari-matrix circuit; the input right and left channel signals are fed directly to the LF and RF channels, while the signals to the LR and RR channels are synthesized from the 2-channel input signals under the control of the DIMENSION control. The LR and RR channel signal components are controlled by the DIMENSION control as shown below.

DIMENSION Control Setting	LR Output	RR Output
Minimum (FCCW)	LF + RF	RF + LF
Center	LF	RF
Maximum (FCW)	LF - RF	RF - LF

When the DIMENSION control is set to the minimum position the LR and RR channel signals become monophonic, to the center are stereophonic, and to the maximum are out of phase, thus providing vanished sound image positioning.

In the SQ DECODER position, signal sources encoded by the CBS SQ system are ideally decoded into 4-channel signals. Required for this operation is incorporation of the SQ Adaptor, Model SQA-1, into the Model 4400.

#### 4.2 Balance Control

Signals from the buffer amplifiers are fed into the balance control circuit, in which the signals are controlled by three balancers: FRONT L-R, REAR L-R, and FRONT-REAR. By setting the FRONT-REAR balancer to the "FRONT" side and the FRONT L-R balancer to the "L" side, for example, only the front left channel is driven.

The balance control circuit is provided with the REMOTE CONTROL switch which makes the Model RC-4 Remote Control Box operative when set to the "REMOTE" position. In the "REMOTE" position the BALANCE and VOLUME controls on the Model 4400 become ineffective since signals are led to the Model RC-4. Balance and volume can be adjusted by the Model RC-4. Balance and Volume controlled signals are led to the tone control amplifier.

### 5. DOLBY NR UNIT

The Dolby units built in the Model 4400, which are two processors, allows you to monitor the Dolbyized recording sound with flat response from the loudspeakers during the Dolbyized recording on the tape recorder. The Dolby unit is inserted in front channels only.

An input signal coming to J601 (J602) is amplified by H601 (H602) and in the playback mode of operation, its output signal is fed to the high-cut filter and is further amplified by H603 and H605. In the record mode of operation, the signal magnified by the H602 is directly amplified by H604 and H606. The signal magnified by H603 and H605 (H604 and H606) comes to the resistance mixing circuit of R623 and R625 (R624 and R626) and to the phase inverting circuit of H607 and H609 (H608 and H610). The output signal is fed out from J607 (J608) to the TAPE MONITOR OUT Jack or amplifiers.

Encoding and decoding in the Dolby circuit are accomplished as follows. In the record mode of operation, the signal from J606 is led to J612 and is discriminated in frequency and level by the dynamic filter consisting of H612, resistor, and capacitor. The discriminated signal is then led to the amplifier of H614 and H616, and its output signal is fed back to the mixing circuit in phase, thus increasing the output level at J608, i.e., "encoded". In the playback mode of operation, a part of the output signal (J607) is fed to J611 and is discriminated in the frequency and level by the dynamic filter consisting of H611, resistor, and capacitor.

The discriminated signal is then fed to the amplifier of H613 and H615, and its output signal is fed back to the mixing circuit out of phase, thus decreasing the output level at J607, i.e., "decoded".

The diodes H626 to H629 function as a limiter. The attached "DOLBY PROCESSING CHART", page 18 will aid in the understanding of the operation of the Dolby circuit.

## **6. 400Hz TONE**

The 400Hz tone signal is a 580mV, 400Hz sine wave fed to the FRONT and REAR TAPE MONITOR OUT jacks at any position of the DOLBY NR switch (with exception of the RECORD II position) and the SELECTOR switch.

The output signal of the 400Hz oscillator consisting of HL01 and HL02 is fed to JL02 and JL03, respectively, through the emitter follower HL03. The output levels at JL02 and JL03 are adjusted to 580mV and approximately 50mV, respectively.

The signal fed from the Dolby P.W. Board comes to JL04 and is rectified through HL06. The rectified output at JL06 is led to the meter M001.

## **7. DOLBY NR SWITCH**

This switch sets the Dolby noise-reduction circuit for record or playback.

### **7.1 Dolby FM**

This position is used for listening to Dolbyized FM broadcasts. The Dolby FM level has been pre-adjusted by RC05 and RC06.

### **7.2 Play**

This position is used to play back a Dolbyized source (except FM).

### **7.3 Off**

With this position, the Dolby circuit is by-passed and the input signals are directly applied to both TAPE MONITOR OUT jacks and amplifiers.

### **7.4 Record I**

For making a Dolbyized recording from an in-coming "flat" (non-Dolbyized) signal. When the MONITOR switch is in the SOURCE (out) position, the "flat" signal will be heard. When the MONITOR switch is in the TAPE (in) position, the "flat" signal will be heard after the Dolbyized signal from the tape has been decoded.

### **7.5 Record II**

For making a "flat" (non-Dolbyized) recording from an in-coming Dolbyized signal.

Regardless of the position of the MONITOR switch, a "flat" signal will be heard.

#### **8. RECORD LEVEL (L) (R)**

These knobs control the record level of the signals to be recorded through the Dolby unit. Adjust the knobs so that the Level Meter pointers of the tape recorder do not exceed the OVU level.

#### **9. PLAY CAL. (L) (R)**

These knobs adjust the playback outputs from a tape deck to the proper Dolby level.

#### **10. DOLBY FM PRESET LEVEL CONTROLS**

These factory-adjusted controls govern FM output level to the Dolby circuit. These controls are for the use of a qualified technician only.

#### **11. 400Hz TONE SWITCH**

This is used for calibration of the record input level of the tape deck. When the switch is depressed, the built-in oscillator operates and a sine wave signal output of 580mV will be applied to the four TAPE MONITOR OUT jacks.

#### **12. FM DE-EMPHASIS SWITCH**

At present both normal and Dolbyized FM broadcast programs are being transmitted with a pre-emphasis time constant of 75 microseconds.

However if the Dolbyized FM broadcasting is approved by the F.C.C., this pre-emphasis time constant for Dolbyized FM broadcast will be changed to 25 microseconds. The FM DE-EMPHASIS switch provided on the rear of Model 4400 is used for switching the time constants. After the permission of Dolbyized FM broadcasting, set the switch to 25 $\mu$ S position. The DOLBY NR switch will automatically change the time constant to 75 $\mu$ S when the DOLBY NR switch is placed in other than DOLBY FM position (namely normal FM broadcast position). Thus, the de-emphasis time constant for each normal and Dolbyized FM reception will be correctly set.

#### **13. HI-LOW FILTER AMPLIFIER**

This hi-low filter amplifier consists of active components HH01 to HH08 which provide a slope attenuation response of 12dB per octave. The signal input to the filter amplifier is passed through a time-constant circuit PS01 comprising a low filter of 50Hz cutoff frequency and a second time-constant circuit comprising a high filter of 9KHz cutoff frequency and is fed to the active components. The active components including NPN- and PNP-type transistors form a direct-coupled amplifier.

#### **14. POWER AMPLIFIER**

This power amplifier is a completely direct-coupled amplifying circuit. The transistors H701 and H702, form the first stage of a differential amplifier, improving the DC stability. The transistor H705 is a current regulating circuit which further improves the DC stability. The transistor H707 and H708, which form the second stage of the differential amplifier, function as driver. The transistor H737 is a current regulating circuit and is the load circuit for H707. The transistors H713 and H714 drive the transistors H003 and H004 which form the power output stage. The transistor H711 is a transistor biasing circuit.

Excessive current flow in the power output stage is detected by the resistor R761 and the resultant variation is applied to the transistors H717, H719 and H721 and cause them to conduct. This decreases the base drive current for H713 and H714. In this way the current flow in the power output stage (H003 and H004) is restricted to a safe predetermined value.

## 15. BTL (Balanced Transformer-less) CONNECTION

This power amplifier is designed to operate in either 2-channel or 4-channel modes, depending on the setting of the POWER MODE switch that incorporates phase-conversion and power switch for BTL connection.

With this switch placed in the 50Wx4 position, this unit operates as a 50W 4 channel amplifier. With the switch placed in the 125Wx2 position, the unit operate as a 125W 2 channel amplifier, in this case, the power output is obtained only from FRONT SPK terminals.

**CAUTION:** When testing this amplifier in the BTL mode (power mode switch set to 125 W x 2), it is mandatory that all test equipment connected to the speaker terminals be isolated from chassis and power line grounds. Additionally, the common or negative (-) speaker terminals of the amplifiers must not be connected together by common leads of the test equipment. **DO NOT GROUND ANY OF THE SPEAKER LEADS.**

## 16. POWER SUPPLY CIRCUIT

- 16.1 Power source for tuner (+13.5V) and stereo beacon (+12V) is zener-regulated (H808) and then filtered by a transistor ripple filter circuit consisting of H818.
- 16.2 Power source for MPX Pre-Amp., Phono-Amp., Pre-Amp. and Buffer/Pre-Amp. (+35V) is fed through a series-regulator circuit consisting of H812.
- 16.3 Both DC plus and minus 14V for the first differential of scope amplifiers are zener-regulated by two zener diodes, H807 and H809, respectively.
- 16.4 DC plus 200V for collector circuit of the vertical and horizontal of scope amplifier and DC minus 600V for CRT's anode are fed by the power supply circuit on P800.

## 17. AUDIO TROUBLE ANALYSIS

1. Excessive line consumption
  - a. Check for shorted transistors H001 through H008.
  - b. Check for shorted transistors H713 through H716.
  - c. Check L003 for short.
2. No line consumption or zero bias
  - a. Check line cord, fuse, shorted H711 & H712, H727 & H728.
  - b. Check for open rectifiers H801~H806 or open L003.
3. Excessive hum and noise level
  - a. Check filter capacitors C002, C003, C709, C710, C713, C714, C715 & C716.
  - b. Check for shorted transistor H812 and H813.
4. Parastic oscillation
  - a. Check for defective capacitors, C002, C003, C705, C706, C707, C708, C717, C718, C719, C720, C721, C722, C723 & C724.
5. Improper clipping
  - a. Check for proper adjustment of R721 and R722.

## 18. SCOPE DISPLAY CIRCUIT

Please, refer to the operating manual on general operating instructions for "SCOPE DISPLAY".

### 18.1 AM Tuning Display

AM signal strength and the correct tuning point are displayed on the scope through the following signal routine;

Rectified DC output at Pin Terminal J151→SELECTOR switch→TUNING DISPLAY switch→RT06 (270K $\Omega$ )→Pin No. 11 of J034→H904 vertical amplifier.

### 18.2 FM Tuning Display

FM signal strength and correct center tuning signals are applied to the oscilloscope's vertical and horizontal deflection plates through the following routines;

- a. Rectified DC output for FM signal strength at the Pin Terminal J209→Pin Terminal J315 →R373 (33K $\Omega$ )→H316 buffer amplifier→R374 (trimming resistor)→Pin Terminal J316→SELECTOR switch→TUNING DISPLAY switch→RT06 (270K $\Omega$ ) Pin No. 11 of J034→H904 Vertical amplifier.
- b. DC plus and minus output for center tuning at the Pin Terminal J204→Terminal J039→R027 (68K $\Omega$ )→Pin Terminal JT06→Trimming resistor RT10 (50K $\Omega$ ) →TUNING DISPLAY switch→RT07 (270K $\Omega$ )→Pin No. 3 of J034 H902 Horizontal amplifier (for center tuning).

Note 1. CT03 is filtering capacitor for audio signals

Note 2. For easy-to-see spot display, the display spot is modulated to have a slight length in vertical direction for FM tuning or in horizontal direction for AM tuning. This is done by applying a small amount of AC voltage for pilot lamps to the vertical (for FM) or Horizontal (for AM) amplifier input terminal Pin No. 9 or Pin No. 6 of J034 respectively.

AC voltage for pilot lamps→RT05→CT01→TUNING DISPLAY switch→SELECTOR switch→Pin No. 6 of J034 (for AM) or Pin No. 9 of J034 (for FM)

Note 3. RT09 is the DC bias adjusting resistor which corrects the spot position at no signal.

### 18.3 FM Multi-Path Display

The multi-path display circuit is almost the same as the FM TUNING DISPLAY circuit except the following:

- a. AC voltage for tuning spot modulation is cut off (RT05 and CT01 are disconnected) from the circuit by depressing the MULTI-PATH push switch.
- b. Audio signal pass filter (CT03) is cut off, this means audio signals developed at J204 are applied to the horizontal amplifier.

The vertical signal which contains multi-path information is the same as that of signal strength and supplied to the R374 through the pin terminal J209.

## 19. SCOPE CIRCUIT DESCRIPTION

### 19.1 Vertical Amplifier

The vertical amplifier consists of two stages of direct-coupled differential amplifiers, the first stage using two FETs (H903 and H904) and the second two transistors (H907 and H908).

It amplifies both AC and DC signals with very high stability.

The first differential amplifier operates as a source follower and no voltage gain is obtained.

The signal passed the first stage is directly fed to the second stage and amplified. The gain of this stage is 47dB for DC signal and 39dB for AC signal. The finally amplified signal is then applied to the oscilloscope tube.

- \* R918 is a gain adjusting resistor and should be set for the gain of 234mV/cm. (at 1KHz, 2 CH DISPLAY position)
- \* R910 is provided for adjusting DC balance between H903 and H904 and should be set so that the voltage difference between the source terminals of H903 and H904 is less than 0.05 volt with vertical centering control knob placed in its mechanical center.

## 19.2 Horizontal Amplifier

The circuitry of horizontal amplifier is almost the same as that of the vertical amplifier.

- \* R917 is gain adjusting resistor and should be set for 234mV/cm (at 1KHz, 2 CH DISPLAY position).
- \* R909 is the DC balance control between H901 and H902 and should be set so that the voltage difference between source terminals of H901 and H902 is less than 0.05 volt with horizontal centering control knob placed in its mechanical center.

## 20. TROUBLE SHOOTING OF OSCILLOSCOPE CIRCUIT

### 20.1 Symptom: No spot obtained

If no spot is obtained with CENTERING knobs (V and H) placed in their mechanical center and BRIGHT control on the rear panel at maximum, there would be defects in the CRT's circuit, vertical and/or horizontal amplifier. To localize the defects proceed as follows:

- a. Short both collector terminals of H907 and H908, and if the spot appear the vertical amplifier would be defective.
- b. Short both collector terminals of H905 and H906, and if the spot appear the horizontal amplifier would be defective.
- c. If no spot is still obtained, the CRT circuit would be defective.

### 20.2 Symptom: Blurred spot

First adjust FOCUS control on the rear panel and if no sharp spot is obtained, check whether the voltage between cathode of CRT (No. 3 terminal) and plate (No. 4 terminal) can be varied from 50V to 250V or not by adjusting FOCUS control on the rear panel. If the voltage varies within the limit above, the oscilloscope circuit is normal. Please, try to replace the CRT with new one.

## CAUTION

### 1. Do not leave the scope turned on with BRIGHT control set maximum.

Do not make the spot left for a long time with its brightness maximum and its focus pin-pointed to avoid possible desensitization of the phosphor. In the case where the scope has to be turned on for a long time, decrease the brightness of the spot. Turn the scope off when not in use.

### 2. High Voltage, Danger

When removing the top and/or bottom cover, always remove the power cord from the AC outlet to avoid possible electrical shock from high voltage for oscilloscope circuit.

### 3. Do not place the set (CRT) in a powerful magnetic field.

If placed, the electron beam in the CRT will be bent and the spot is shifted from the correct position. The trace may also be distorted.

## 21. TEST EQUIPMENT REQUIRED FOR SERVICING

Table 1 lists the test equipment required for servicing the Model 4400 Receiver.

Item	Manufacturer and Model No.	Use
AM Signal Generator		Signal source for AM alignment.
Test Loop		Used with AM Signal generator.
FM Signal Generator	Less than 0.3% distortion	Signal source for FM alignment.
Stereo Modulator	Less than 0.3% distortion	Stereo separation alignment trouble shooting.
Frequency Counter		MPX Oscillator adjustment (VCO).
Audio Oscillator	Weston Model CVO-100P, less than 0.02% residual distortion is required.	Sinewave and squarewave signal source.
Oscilloscope	High sensitivity with DC horizontal and vertical amplifiers.	Waveform analysis and trouble shooting and ASO alignment.
VTVM	With AC, DC, RF range	Voltage measurements.
Circuit Tester		Trouble shooting.
AC Wattmeter	Simpson, Model 380	Monitors primary power to Amplifier.
AC Ammeter	Commercial Grade (1-10A)	Monitors amplifier output under short circuit condition.
Line Voltmeter	Commercial Grade (0-150V AC)	Monitors potential of primary power to amplifier.
Variable Autotransformer (0-140V AC, 10 amps)	Powerstat, Model 116B	Adjusts level of primary power to amplifier.
Shorting Plug	Use phono plug with 600 ohm across center pin and shell.	Shorts amplifier input to eliminate noise pickup.
Output Load (8 ohms, $\pm 1\%$ 150W)	Commercial Grade	Provides 8-ohm load for amplifier output termination.
Output Load (4 ohms, $\pm 1\%$ 150W)	Commercial Grade	Provides 4-ohm load for amplifier output termination.

Table 1. Test Equipment Required for Servicing

## 22. SCOPE DISPLAY ALIGNMENT

- 22.1 Turn the SELECTOR switch to the "CD-4/AUX" position.
- 22.2 Depress both SCOPE DISPLAY switches "ON" and "AUDIO DISPLAY".
- 22.3 Adjust two CENTERING knobs to bring the spot into the center of small circular.
- 22.4 Adjust "BRIGHT" control (R022) on the rear panel to make the brightness of the spot dimmer.
- 22.5 Adjust "FOCUS" control, (R023) to make the spot smaller and more circular.

- 22.6 Feed in 775mV (1KHz) to the "CD-4/AUX INPUTS, FRONT R" jack and adjust R917 (HORIZ) to obtain a horizontal deflection of about 3.3cm, then connect the same input voltage to the "FRONT L" jack and adjust R918 (VERT) for the same vertical deflection.
- 22.7 Set both the centering knobs at their mechanical center, and adjust R909 (HORIZ) and R910 (VERT) to bring the spot into the center of small circle.

### **23. AM TUNING DISPLAY ALIGNMENT**

- 23.1 Depress both SCOPE DISPLAY switches "ON" and "TUNING" and SELECTOR switch to "AM".
- 23.2 Adjust RT09 to bring the spot on the lower center of the base line with no station tuned in.

### **24. FM TUNING DISPLAY ALIGNMENT**

- 24.1 Depress both SCOPE DISPLAY switches "ON" and "TUNING" and SELECTOR switch "FM".
- 24.2 Connect FM signal input of 100K $\mu$ V (98MHz, 400Hz, 30% Mod.) to the FM ANTENNA terminal and adjust R374 so that the spot does not frame out.
- 24.3 FM Multipath display alignment: Adjust RT10 to obtain full deflection of the trace within both side marks, applying FM signal (1K $\mu$ V, 400Hz, 100% Mod.) to the FM ANTENNA terminals.

### **25. AM ALIGNMENT PROCEDURE**

#### **25.1 AM IF Alignment**

1. Connect a sweep generator to the J153 and an alignment scope to the test point ③.
2. Rotate each core of IF transformer L153 and L154 for maximum height and flat top symmetrical response.

#### **25.2 AM Frequency Range and Tracking Alignment**

1. Set AM signal generator to 525KHz. Turn the tuning capacitor fully closed (place the tuning pointer at the low end.) and adjust the oscillator coil L152 for maximum audio output.
2. Set the signal generator to 1650KHz. Place the tuning pointer in the high frequency end and adjust the oscillator trimmer on the oscillator tuning capacitor for maximum audio output.
3. Repeat the step 1 and 2 until no further adjustment is necessary.
4. Set the generator to 600KHz and tune the receiver to the same frequency and adjust a slug core of AM ferrite rod antenna and RF coil L151 for maximum output.
5. Set the generator to 1400KHz and tune the receiver to the same frequency and adjust both trimming capacitors of antenna and RF tuned circuit for maximum output.
6. Repeat the step 4 and 5 until no further adjustment is necessary.

Note: During tracking alignment reduce the signal generator output as necessary to avoid AGC action.

#### **25.3 AM Signal Strength Display Adjustment**

Set the AM Signal generator to 1000KHz with 100dB/m, and adjust R152 so that the spot may meet upper mark.

### **26. FM ALIGNMENT PROCEDURE**

1. Connect an FM signal generator to the FM ANTENNA terminals and an oscilloscope and an audio distortion analyzer to the TAPE MONITOR OUT jacks on the rear panel.
2. Set the FM SG to 87.5MHz and provide about 3 to 5 $\mu$ V. Place the tuning pointer at the low frequency end by rotating the tuning knob and adjust the core of oscillator coil L105 to obtain maximum audio output.



3. Set the FM SG to 108.5MHz and provide about 3 to 5 $\mu$ V output. Rotate the tuning knob and place the tuning pointer at the high frequency end and adjust the trimming capacitor C106 for maximum output.
4. Repeat the step 2 and 3 until no further adjustment is necessary.
5. Set the FM SG to 90MHz and tune the receiver to the same frequency. Decrease signal generator output until the audio output level decreases with the decreasing generator output. Adjust the antenna coil L101, RF coil L102, L103 and L104 and IF transformer L106 for minimum audio distortion.
6. Set the FM SG to 106MHz and tune the receiver to the same frequency. Adjust the trimming capacitors of antenna and RF tuning circuits for minimum distortion (C102, C103, C104, C105).
7. Repeat the step 5 and 6 until no further adjustment is necessary.
8. Connect a VTVM (with DC 1V range) across the pin terminal J204 and common ground. Adjust the secondary core (upper) of discriminator transformer L201 so that the VTVM indicates null reading (zero reading) at no signal. Set the FM SG to 98MHz and increase its output level to 1K $\mu$ V and tune the receiver to the same frequency so that the VTVM gives null reading. Next adjust the primary core (lower) of L201 for minimum distortion. (Scope display can, of course, be used as tuning indicator instead of the VTVM, if the scope unit has been correctly adjusted as instructed in the SCOPE DISPLAY ALIGNMENT.)
9. Set the FM SG to 98MHz with 100K $\mu$ V, and adjust R374 so that signal strength indicator spot just reaches upper mark.

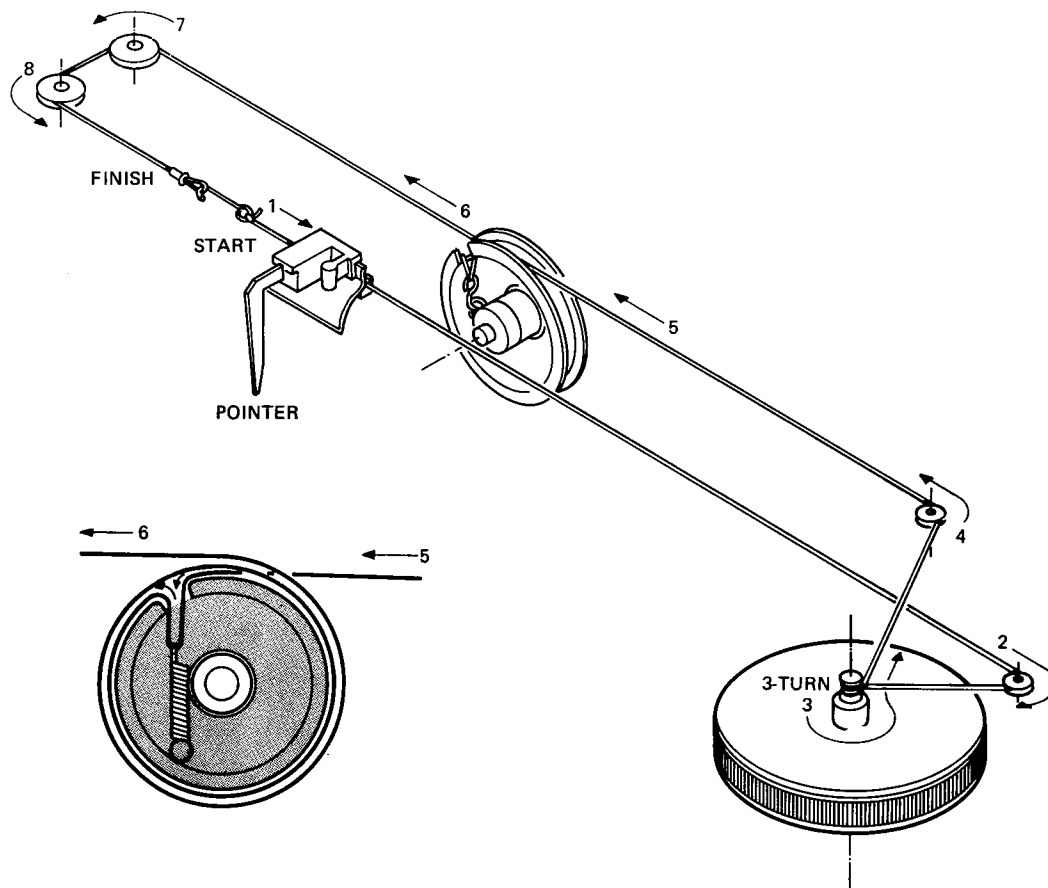

Figure 2. Dial Stringing

### 26.1 Stereo Separation Alignment

1. Set the FM SG to provide  $1K\mu V$  at 98MHz. Tune the receiver to the same frequency so that the tuning indicator spot indicates its center. Then turn off the modulation of the FM SG, connect a frequency counter to test point J310 (point ©) and adjust R311 so that the frequency counter may a precisely read 19KHz.
2. Modulate the FM SG with stereo composite signal consisting of only L or R channel (of course a pilot signal must be included).
3. Adjust the trimming resistor R301 for maximum and same separation in both channels.

### 26.2 Muting Circuit Alignment

1. Connect a VTVM to the tap of the resistor R363 and adjust the resistor R363 until the meter reads 0.75V DC at no signal.
2. Set the FM SG to provide  $1K\mu V$  at 98MHz and tune the receiver to the same frequency correct.
3. Turn on MUTING push-switch. Shift the FM signal generator frequency to plus and minus and note both plus and minus shifted frequencies at which undesirable audio side responses are muted out. Adjust the R363 so that the same shifted frequencies mute the undesirable side response.
4. Adjust R362 for preferred frequency shift at which the muting circuit operates.

## 27. AUDIO ADJUSTMENT

1. Connect a VTVM to No. 11 of J036(+) and No. 9 of J036(-) and adjust the trimming resistor R739 until the VTVM reads 12mV DC. For the other channel connect the VTVM to No. 33 of J036(+) and No. 35 of J036(-) and adjust the R740 for the same reading.
2. Connect a VTVM to No. 13 of J036(+) and No. 15 of J036(-) and adjust the trimming resistor R721 until the VTVM reads 0V DC. For the other channel connect the VTVM to No. 31 of J036(+) and No. 29 of J036(-) and adjust the R722 until the VTVM reads 0V-DC.

## 28. AUTOMATIC VOLTAGE REGULATOR ADJUSTMENT

Connect a VTVM to JM03(+) and JM04(-) and adjust R810 until the VTVM reads 35V under no signal condition.

## 29. DOLBY ALIGNMENT PROCEDURES

For adjustment of the Dolby unit, an alignment fixture should be built up based on the Fig. 3 circuit diagram. Then, using the alignment fixture proceed as follows.

1. A) Set the REC/PB switch to REC, the DOLBY ON/OFF switch to OFF (close), and the FET GATE switch to OFF (close).  
 B) Adjust the semi-fixed resistor R654 until the source voltage for the FET (H612) becomes maximum (positive).  
 C) Feed in 5KHz at a level to give 17.5mV at J606.  
 D) Note signal level obtained at the OUTPUT terminal.  
 E) Set the DOLBY ON/OFF switch to ON (OPEN) and adjust gain control (R660) for a  $10\pm 0.25$ dB rise at the OUTPUT terminal.  
 F) Note level at OUTPUT terminal with DOLBY ON/OFF switch ON.  
 G) Set the FET GATE to ON and adjust low control (R654) for a  $2\pm 0.25$ dB drop at output terminal.  
 H) Check the level setting at Step C) to G)
2. A) Set the REC/PB switch to PB, the DOLBY ON/OFF switch to OFF (close), and the FET GATE switch to OFF (close).  
 B) Adjust the semi-fixed resistor R653 until the source voltage for the FET (H611) becomes maximum (positive).

- C) Feed in 5KHz at a level to give 44mV at J605.  
 D) Note signal level obtained at the OUTPUT terminal.  
 E) Set the DOLBY ON/OFF switch to ON and adjust gain control (R659) for a  $10 \pm 0.25$ dB fall at the OUTPUT terminal.  
 F) Note level at OUTPUT terminal with DOLBY ON/OFF switch ON.  
 G) Set the FET GATE to ON and adjust low control (R653) to give a rise of  $2 \pm 0.25$ dB at the OUTPUT terminal.  
 H) Check the level setting at Step C) to G).
3. For the level adjustment, set the DOLBY NR switch and SELECTOR switch to the RECORD I and CD-4/AUX positions, respectively, and use the TAPE MONITOR OUT jack for the output signal. By setting the 400Hz TONE pushswitch "in", the 400Hz sine wave is fed out. Adjust the semi-fixed resistor RL11 for 580mV of the sine wave output voltage in both R and L channels. Then, connect the 400Hz 580mV signal at TAPE 1 R and L OUTPUT Jacks to the TAPE 1 R and L INPUT Jacks with external shielded leads. Place "MONITOR" switch in TAPE 1 position. Adjust the semi-fixed resistors RL28 and RL29 until the DOLBY LEVEL meter indicates Dolby level. Change over the METER switch, and perform this adjustment for both R and L channels.  
 Next adjust the semi-fixed resistor RL12 for 580mV output level when the DOLBY NR switch is set to the OFF position. Check this output level after the adjustment of the level setting semi-fixed resistors RL11 and RL12. The output level must be precisely 580mV since it is a reference voltage level in the Dolby circuit.

### 30. ALIGNMENT PROCEDURES FOR DOLBY FM PRESET LEVEL CONTROLS

Connect an FM signal generator to the FM antenna. Set the modulation frequency and deviation of the FM signal generator to 400Hz and 50% (with PILOT carrier).

Set the FM signal generator to 98MHz and the DOLBY NR switch to the OFF position. Turn the Tuning knob on Model 4400 unit it tunes to the 98MHz signal from the FM signal generator.

Then, set the DOLBY NR switch to the DOLBY FM position, and adjust the FM preset level controls RC05 and RC06 so that the DOLBY LEVEL meter may point the Dolby FM level. Change over the METER switch, and perform this adjustment for both R and L channels.

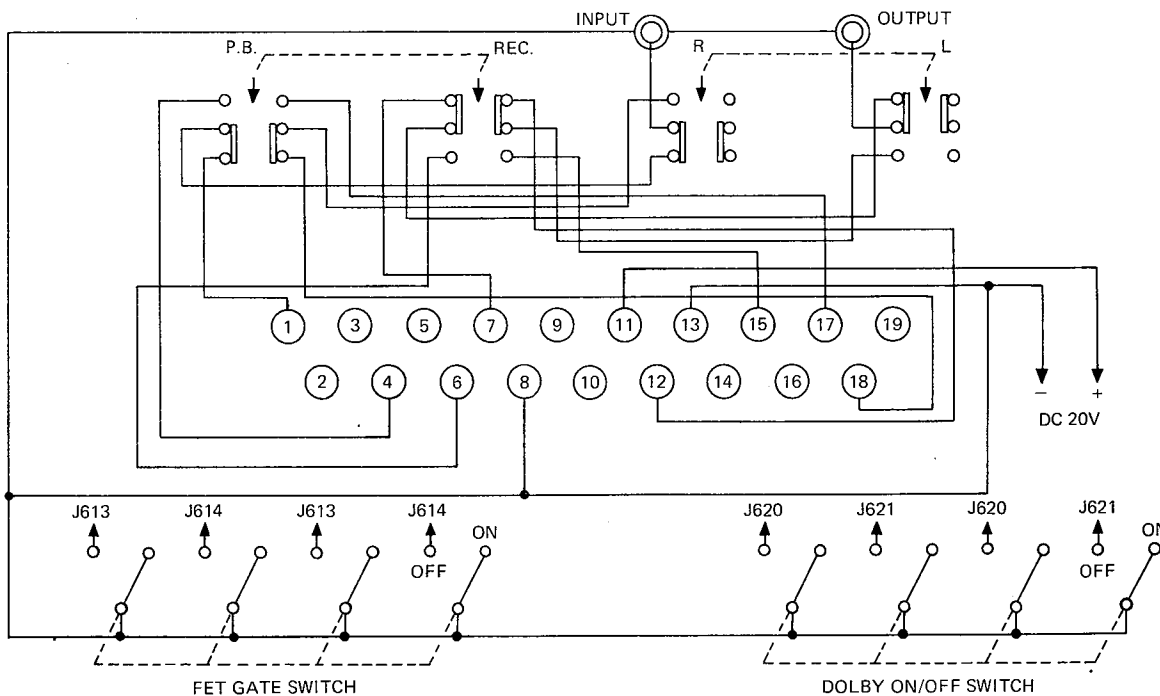

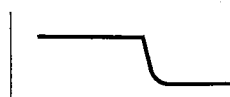
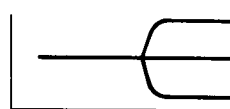

Figure 3. Dolby Alignment Fixture Schematic

### 31. EXPLANATION OF THE DOLBY PROCESSING CHART

This chart shows the condition of the signals available at the speakers (SPKRS) and at the TAPE MONITOR OUT terminals as a function of different control settings.

To understand the chart refer to the symbols below:

- 
 — Represents a signal which has not been applied to either Record or Playback Dolby circuits. The relative amplitudes of all audio frequencies remain unaltered at all levels.
- 
 — Represents a signal which has been processed by the Dolby Record circuit. The relative amplitude of the high frequencies is increased at low signal levels.
- 
 — Represents a signal which has been processed by the Dolby Playback circuit. The relative amplitude of the high frequencies is decreased at low signal levels.
- 
 — Represents a signal which has been processed by both the Record and the Playback Dolby circuits.

These circuits are complementary. Therefore, relative amplitudes of all audio frequencies are restored to their original values.

SIGNAL	DOLBY SW		PLAY						OFF						RECORD						
	TAPES MON		DOLBY FM		SOURCE		TAPE		SOURCE		TAPE		SOURCE		TAPE		SOURCE		TAPE		
	↑	↑	SOURCE	TAPE	SPKRS	TAPE OUT	SPKRS	TAPE OUT	SPKRS	TAPE OUT	SPKRS	TAPE OUT	SPKRS	TAPE OUT	SPKRS	TAPE OUT	SPKRS	TAPE OUT	SPKRS	TAPE OUT	
FM TRANSMISSION																					
NORMAL FM		↑																			
		↑																			
75 μS FM WITH DOLBY		*																			
		**																			
DOLBY FM (25 μS W/DOLBY)		*																			
		**																			
OTHER SOURCE																					

NOTE: \* DE-EMPHASIS SWITCH IN THE 75 μS POSITION.  
 \*\* DE-EMPHASIS SWITCH IN THE 25 μS POSITION.

Table 2. Dolby Processing Chart

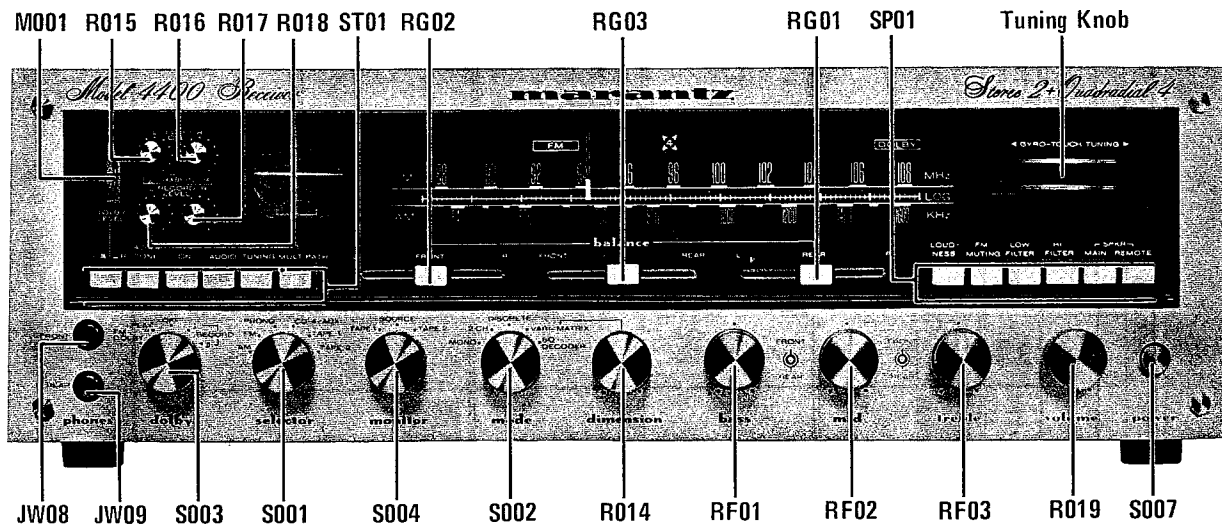

Figure 4. Front Panel Adjustment and Component Locations

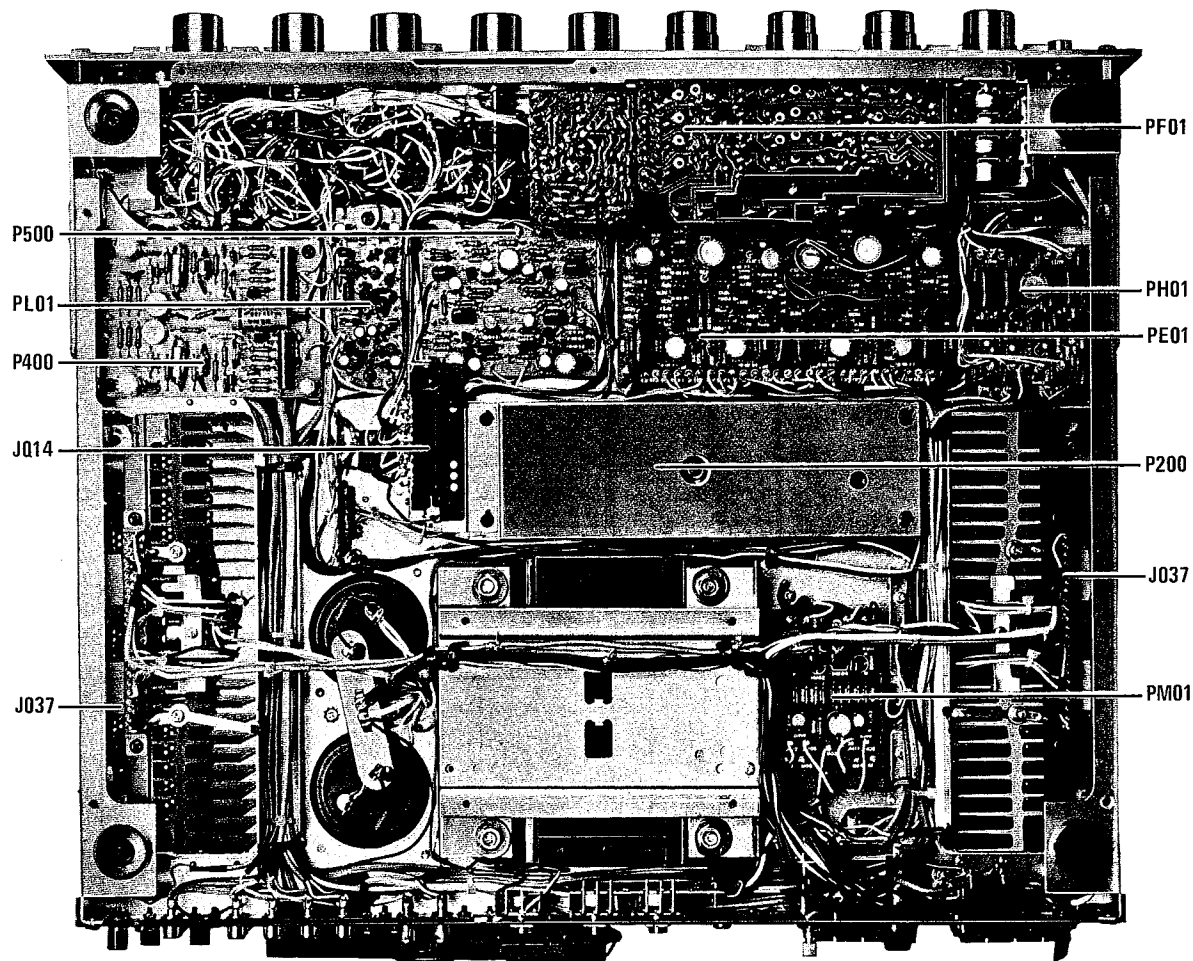

Figure 5. Main Chassis Component Locations (Bottom View)

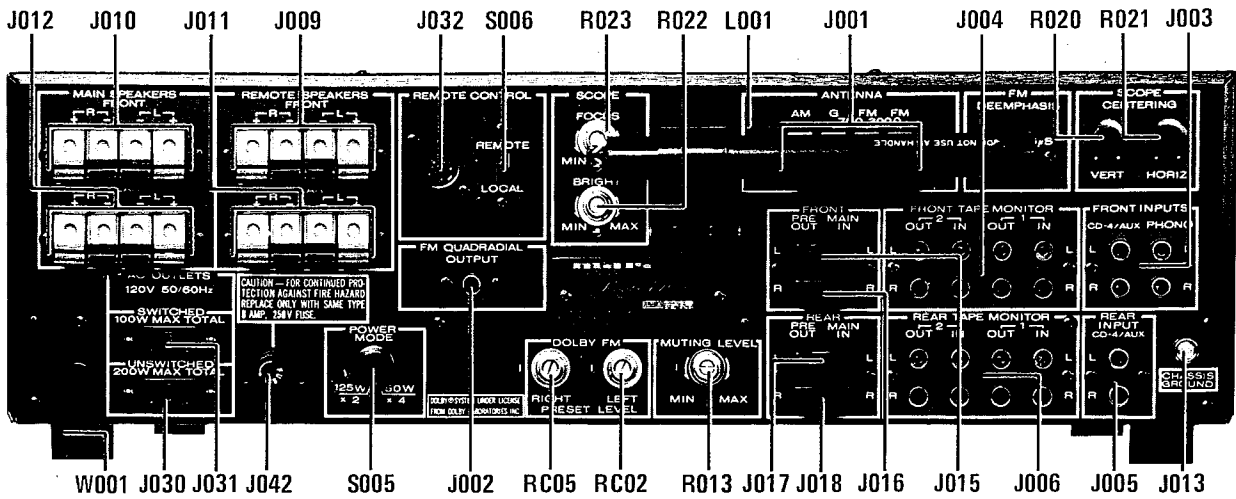

Figure 6. Rear Panel Adjustment and Component Locations

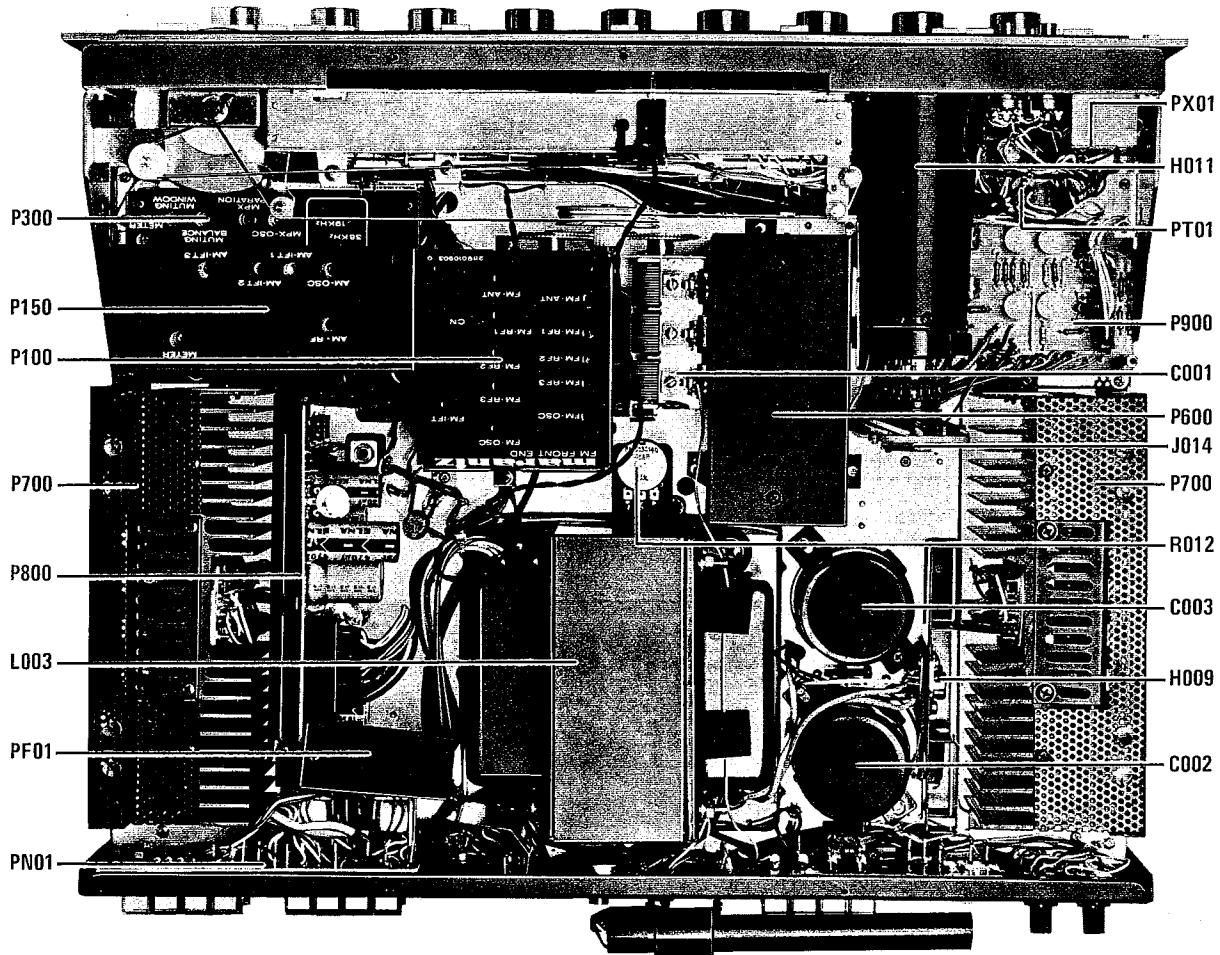

Figure 7. Main Chassis Component Locations (Top View)

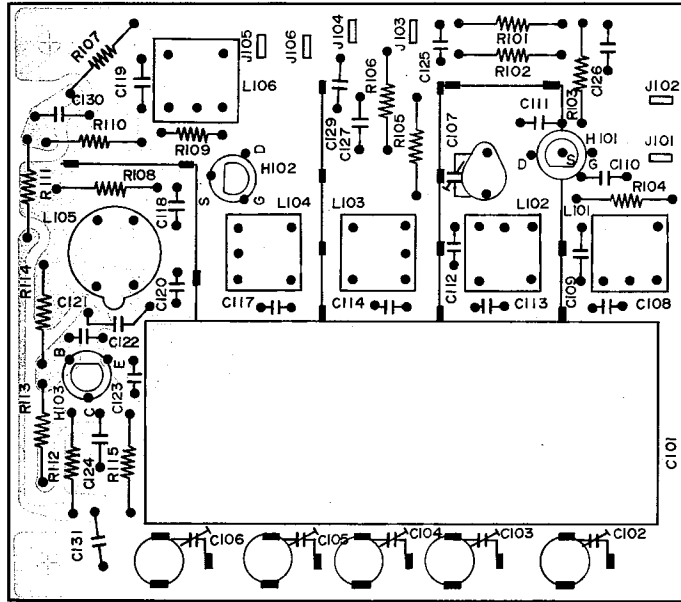
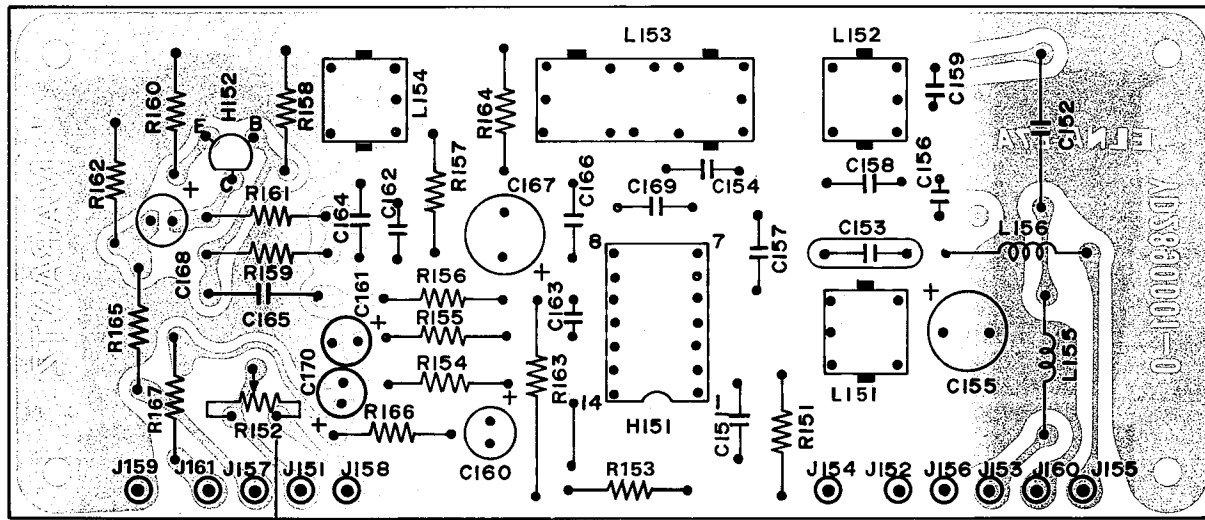

Figure 8. FM Front End Assembly P100 Component Locations



AM Tuning  
Display Adj.

Figure 9. AM Tuner Assembly P150 Component Locations

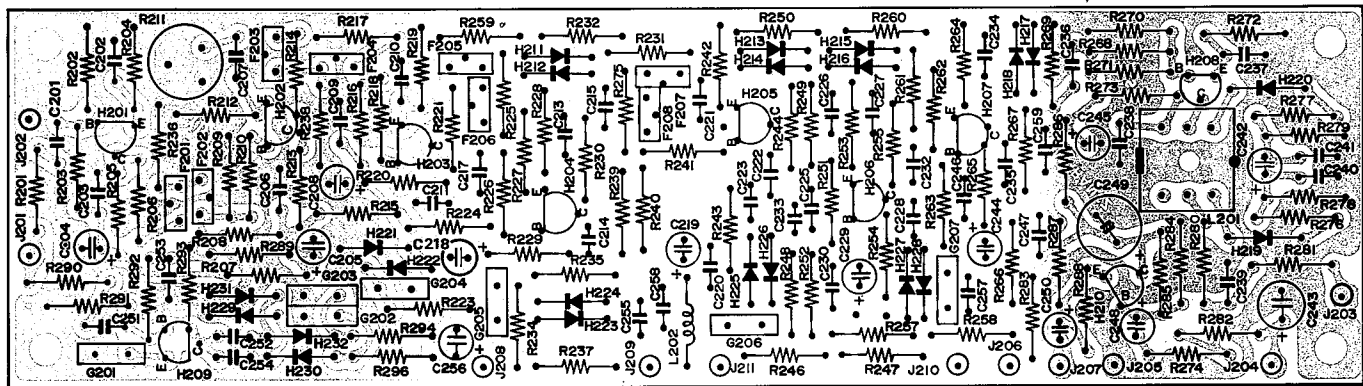

Figure 10. FM IF Amplifier Assembly P200 Component Locations



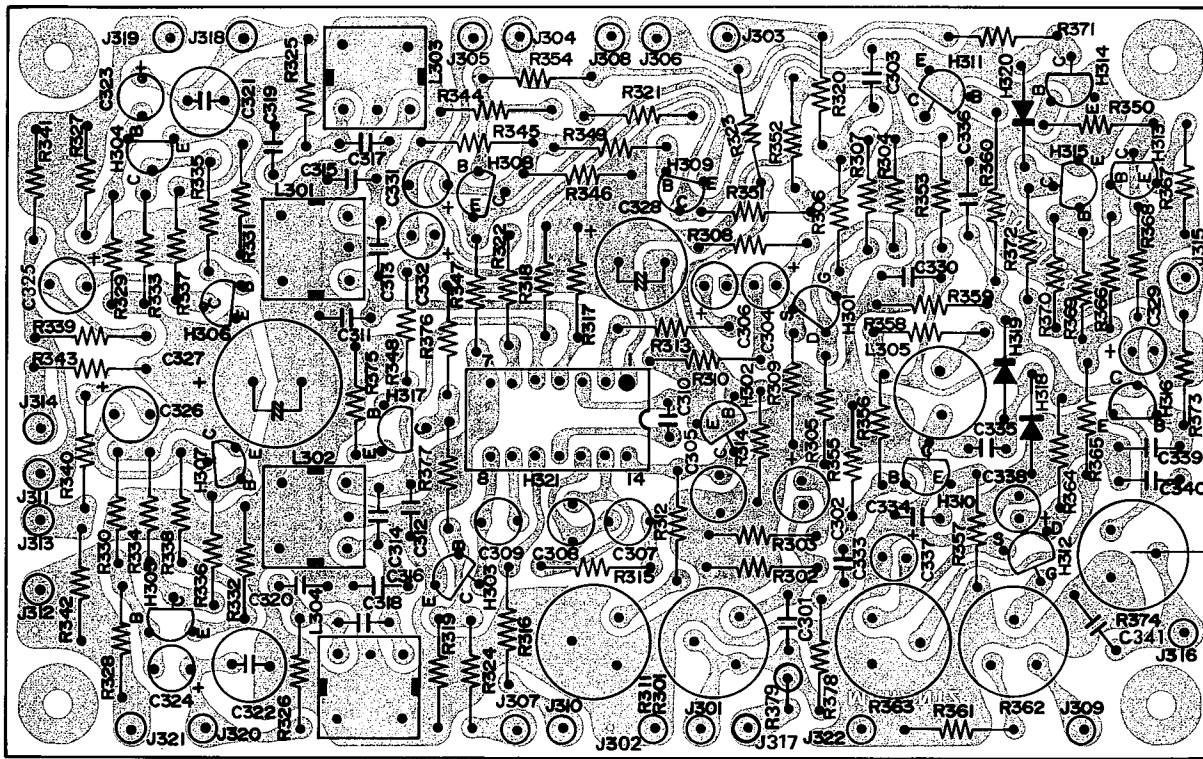

Figure 11. MPX Stereo Decoder, Noise and DC Amplifier Assembly P300 Component Locations

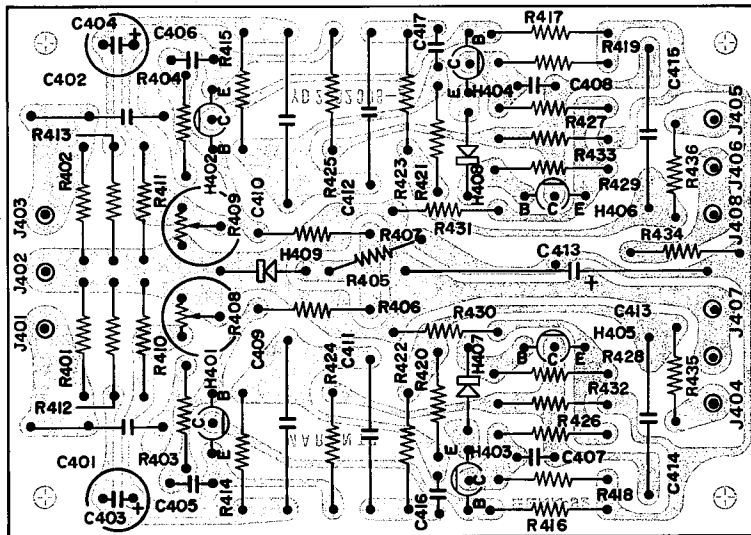

Figure 12. Phono Amplifier Assembly P400 Component Locations

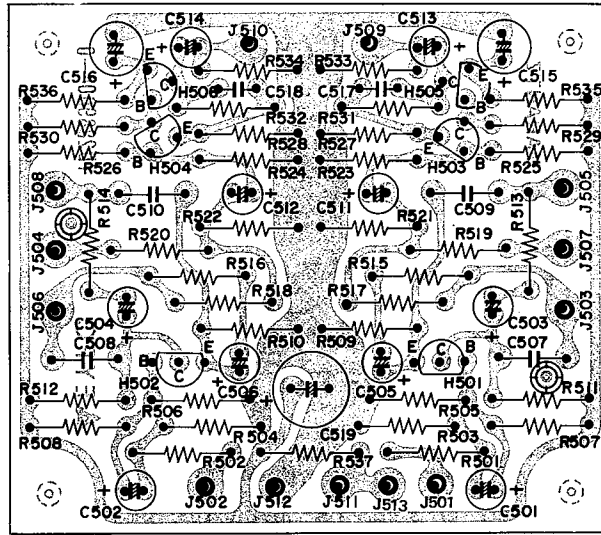

Figure 13. Vari-Matrix Assembly P500 Component Locations

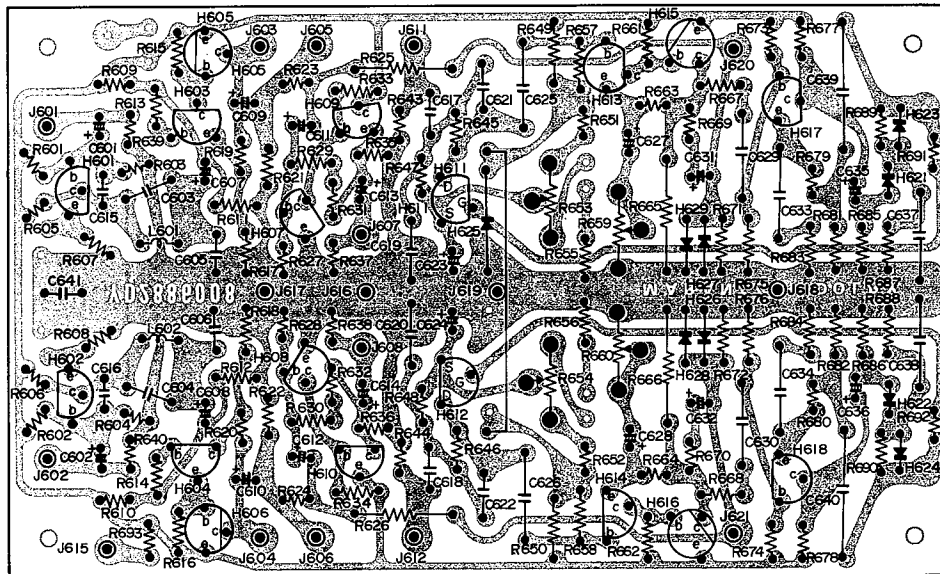

Figure 14. Dolby Unit Assembly P600 Component Locations

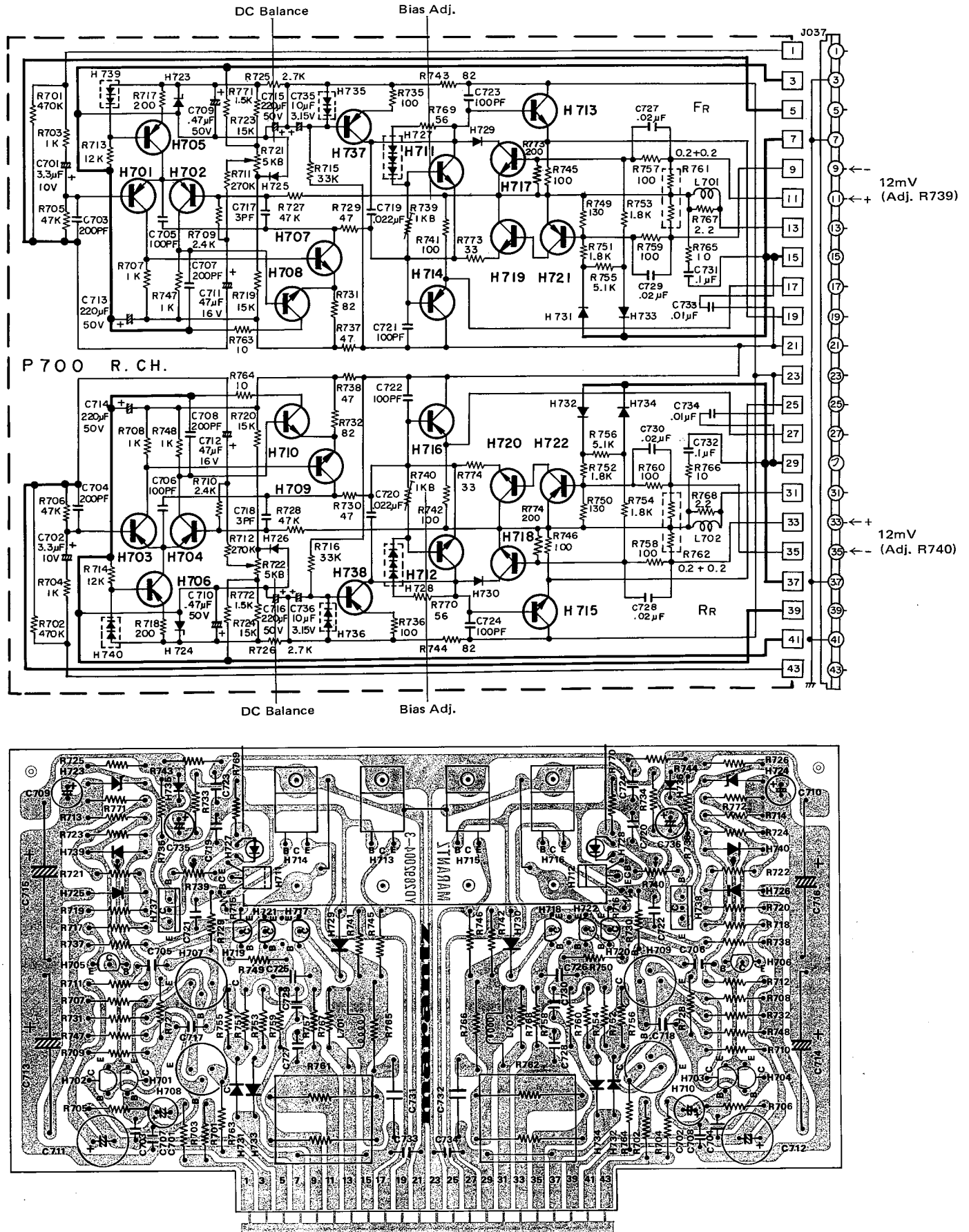

Figure 15. Power Amplifier Assembly P700 Component Locations and Schematic Diagram

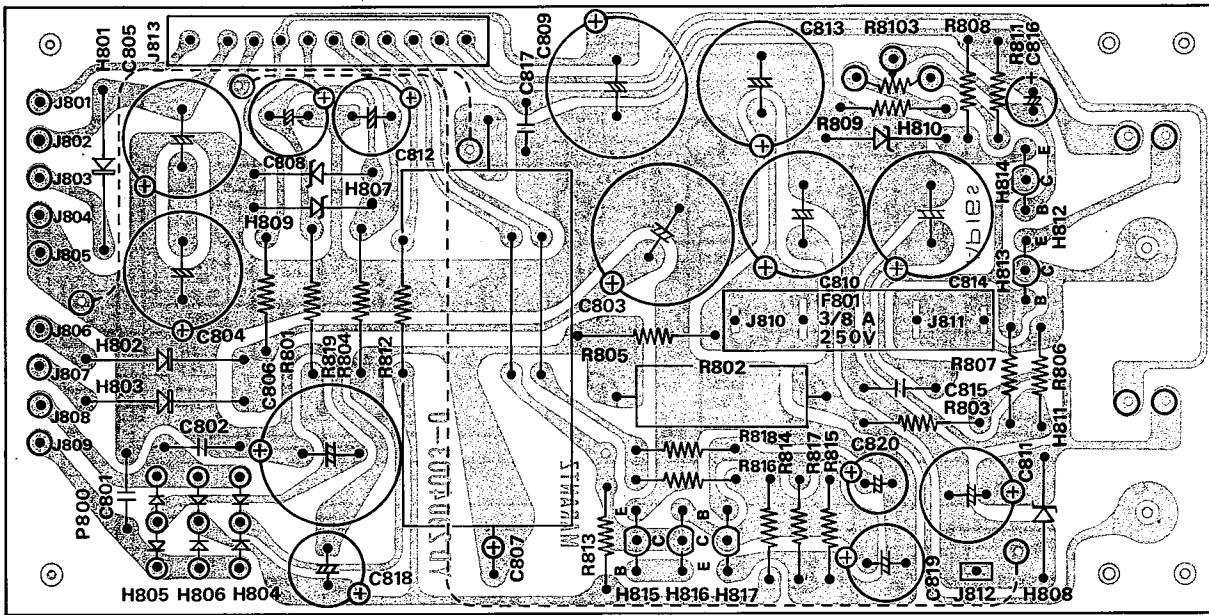

Figure 16. Power Supply Assembly P800 Component Locations

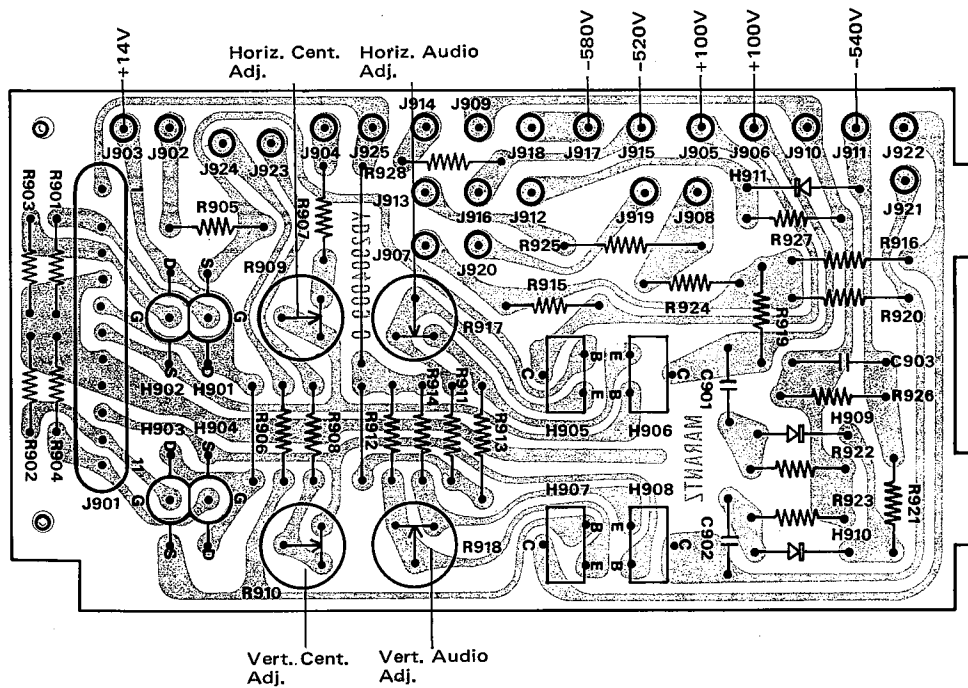

Figure 17. Scope Display Amplifier Assembly P900 Component Locations

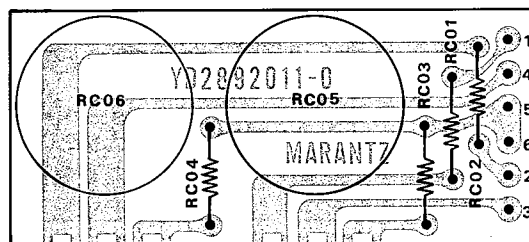

Figure 18. FM Cal. Assembly PC01 Component Locations

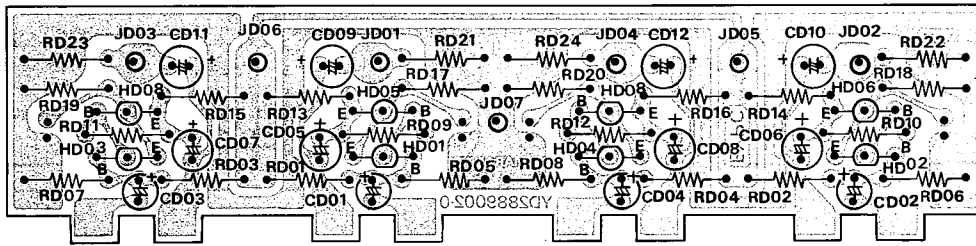

Figure 19. Tone Amplifier Assembly PD01 Component Locations

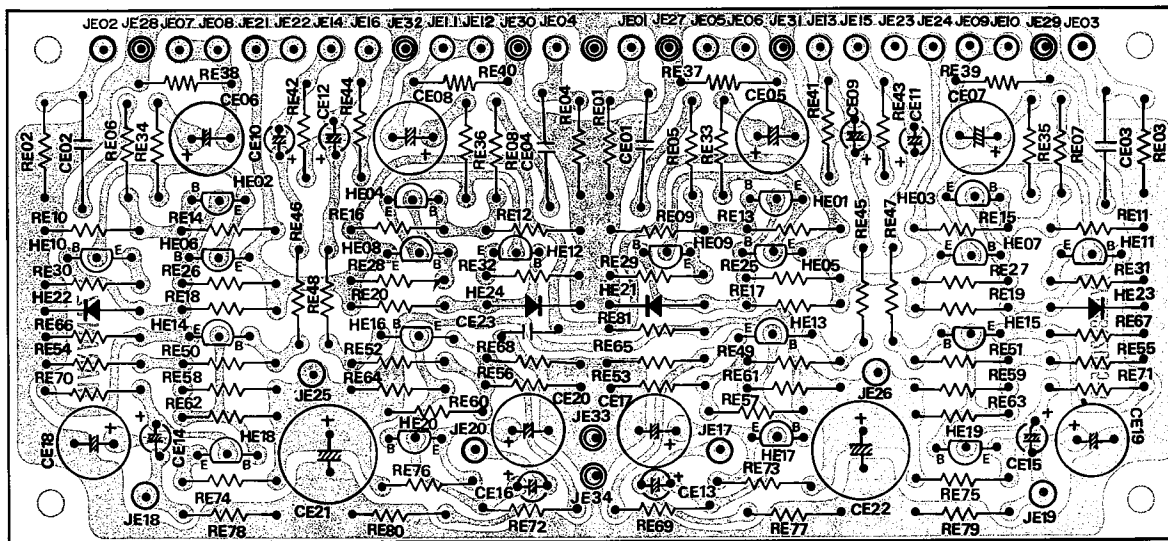

Figure 20. Buffer and Pre-Amplifier Assembly PE01 Component Locations

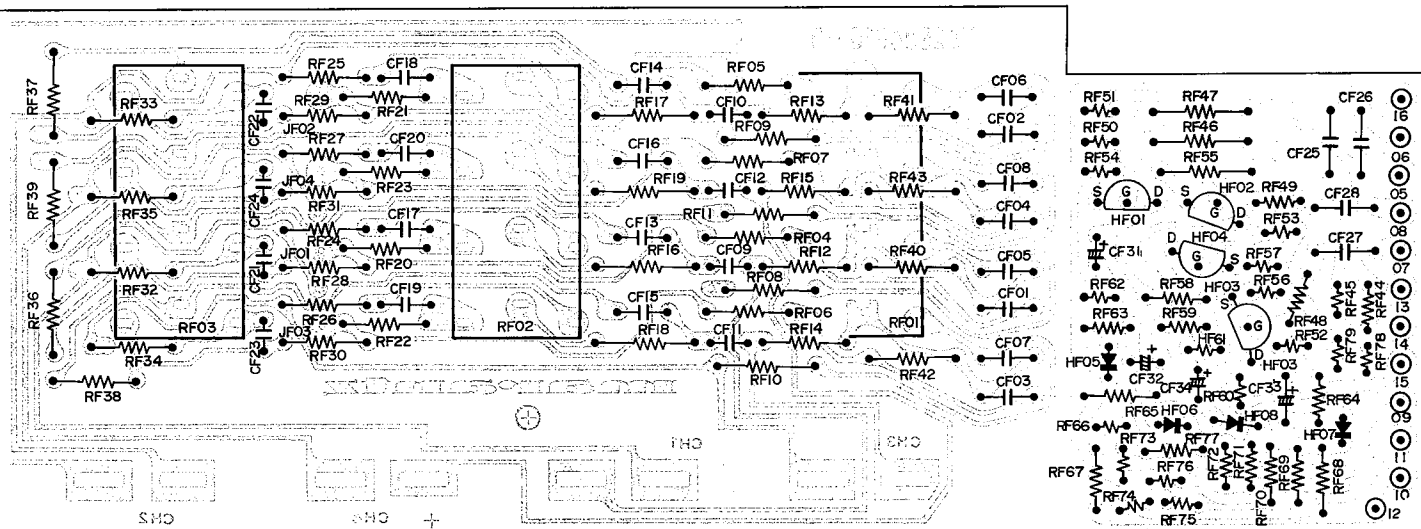

Figure 21. Tone Control Unit and Diode Matrix Assembly PF01 Component Locations

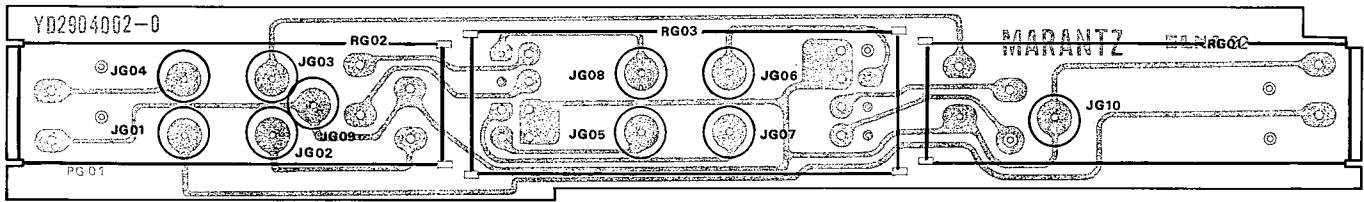

Figure 22. Balance Control Unit Assembly PG01 Component Locations

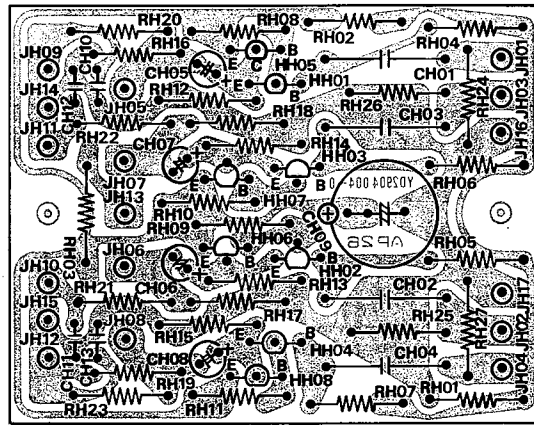

Figure 23. Filter Amplifier Assembly PH01 Component Locations

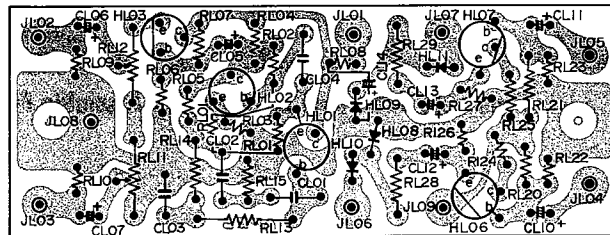

Figure 24. 400Hz Oscillator and Meter Driver Assembly PL01 Component Locations

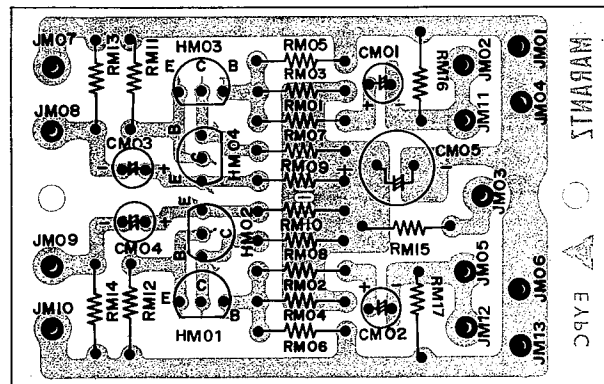

Figure 25. Phase Converter Assembly PM01 Component Locations

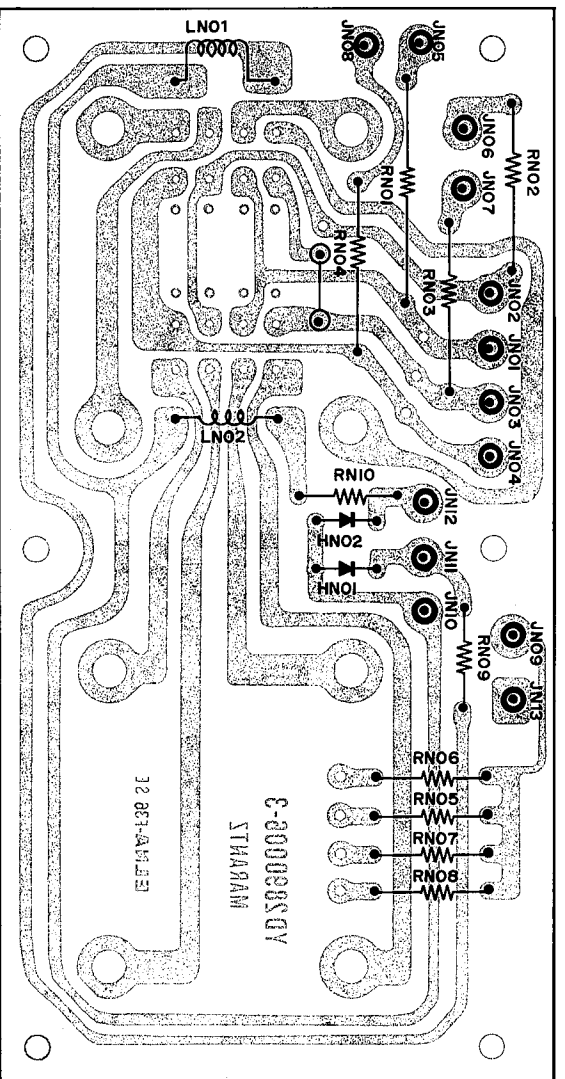

Figure 26. Speaker Protector Assembly PN01 Component Locations

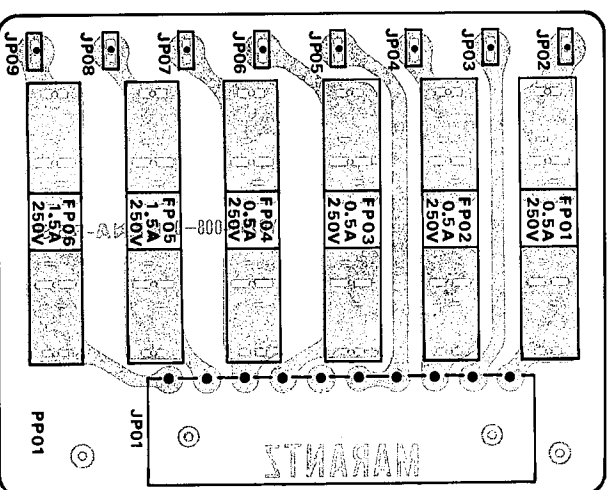

Figure 27. Fuse Unit Assembly PP01 Component Locations

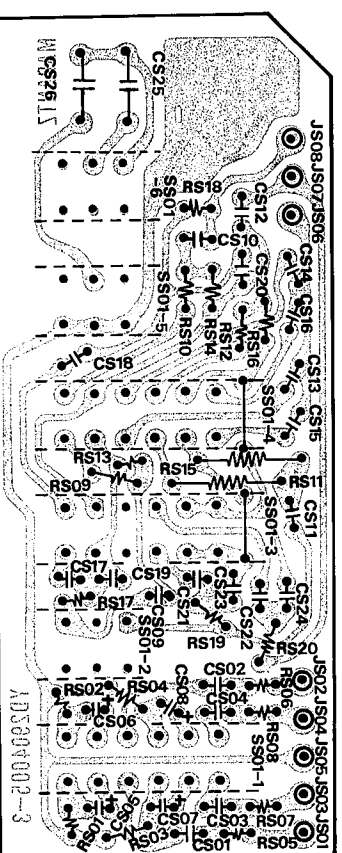

Figure 28. Switch Unit Assembly PS01 Component Locations

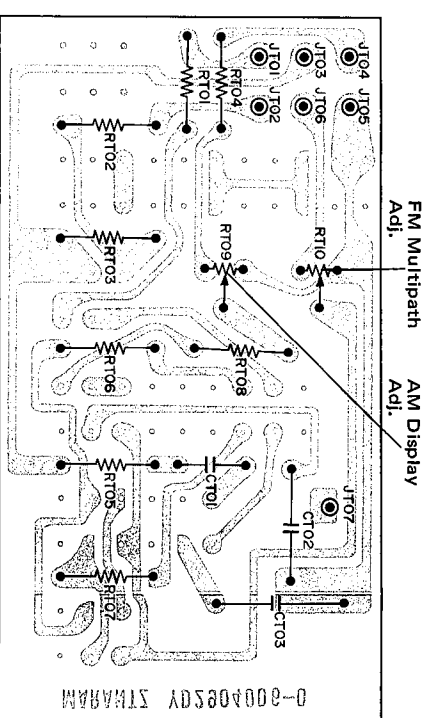

Figure 29. Switch Unit Assembly PT01 Component Locations

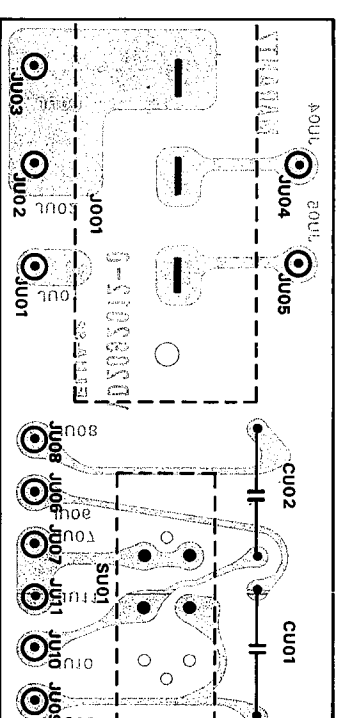

Figure 30. FM De-emphasis Assembly PU01 Component Locations

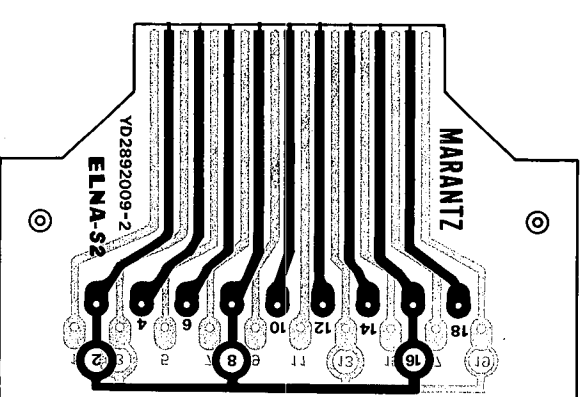

Figure 31. Dolby Terminal Assembly PV01 Component Locations

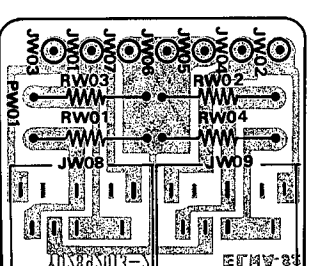

Figure 32. Headphone Assembly PW01 Component Locations

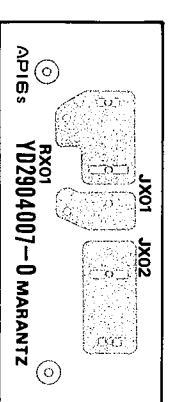

Figure 33. Meter Lamp Assembly PX01 Component Locations



Figure 34. Selector Lamps Assembly PY01 Component Locations

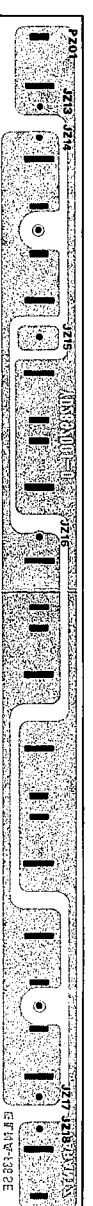

Figure 35. Dial Lamps Assembly PZ01 Component Locations

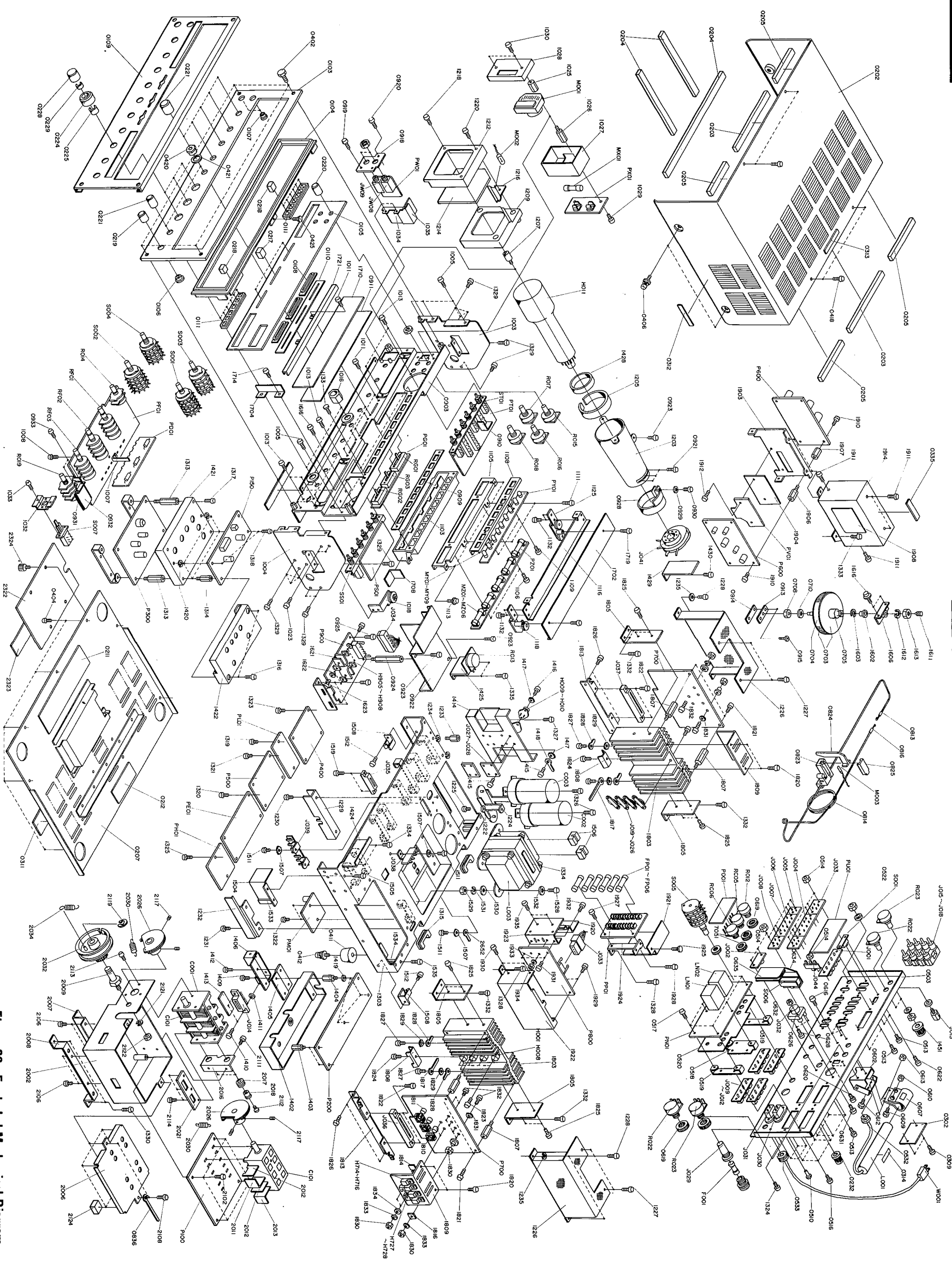

Figure 36. Exploded Mechanical Diagram



**PARTS LIST**

REF. DESIG.	PART NO.	DESCRIPTION	REF. DESIG.	PART NO.	DESCRIPTION
A	290406340	Front Panel Assembly, For U.S.A.			<b>P100-RESISTORS</b>
A1	290406341	Front Panel Assembly, For CANADA			All resistors $\pm 5\%$ and $\frac{1}{4}W$ .
0103	290406301	Escutcheon, Front Panel	R101	RT0556314	56K $\Omega$
0104	289240101	Frame	R102	RT0510514	1M $\Omega$
0105	290415801	Window	R103	RT0510414	100K $\Omega$
0106	281825105	Bush	R104	RT0510114	100 $\Omega$
0107	273125901	Bush x 2	R105	RT0522114	220 $\Omega$
0108	285425901	Bush x 3	R106	RT0510114	100 $\Omega$
0109	289205301	Cover, For U.S.A., Front Panel Protector	R107	RT0510114	100 $\Omega$
0110	290410701	Sheet	R108	RT0547214	4.7K $\Omega$
0111	290425901	Bush x 2	R109	RT0522314	22K $\Omega$
			R110	RT0510214	1K $\Omega$
B	289225740	Bottom Cover Assembly	R111	RT0510114	100 $\Omega$
0207	289225750	Lid K, Ass'y, Bottom	R112	RT0510114	100 $\Omega$
0212	288612005	Insulator	R113	RT0522314	22K $\Omega$
			R114	RT0522314	22K $\Omega$
			R115	RT0512214	1.2K $\Omega$
C	281815440	Knob Assembly, Bass, Mid., Treble			<b>P100-CAPACITORS</b>
0224	281815404	Knob	C101	CA5000001	Variable, FM 5 Gang
0225	71400149Q	Spring	C102	CT1100001	Trimming, 1.5 ~ 11.5PF NPO
			C103	CT1100001	Trimming, 1.5 ~ 11.5PF NPO
D	281815441	Knob Assembly, Bass, Mid., Treble	C104	CT1100001	Trimming, 1.5 ~ 11.5PF NPO
0228	281815405	Knob	C105	CT1100001	Trimming, 1.5 ~ 11.5PF NPO
0229	71400159Q	Spring	C106	CT1100001	Trimming, 1.5 ~ 11.5PF NPO
			C107	CT1100002	Trimming, 1.5 ~ 11.5PF NPO
E	290416040	Rear Panel Assembly	C108	DD1615001	Ceramic, 15PF $\pm 10\%$ , 50V
0503	290416001	Bracket	C109	DK1710201	Ceramic, 1000PF $\pm 20\%$ , 50V
0510	55060365S	T.R. Rivet x 4	C110	DK1810301	Ceramic, 0.01 $\mu$ F +100%, -0%
J030	YJ0400048	Jack, AC Outlet			
J031	YJ0400048	Jack, AC Outlet	C111	DD1105001	Ceramic, 5PF $\pm 0.5$ PF
			C112	DK1710201	Ceramic, 1000PF $\pm 20\%$
F	285327340	Fly Wheel Assembly	C113	DD1615001	Ceramic, 15PF $\pm 10\%$
0703	257706302	Escutcheon x 2	C114	DD1625001	Ceramic, 25PF $\pm 10\%$
0704	257727301	Fly Wheel	C115	DD1001002	Ceramic, 1.0PF $\pm 0.25$ PF
0705	285311201	Shaft	C116	DD1600601	Ceramic, 0.6PF $\pm 10\%$
0708	53110603E	Hexagon Nut	C117	DD1620001	Ceramic, 20PF $\pm 10\%$
0710	54020601E	Flat Washer	C118	DK1710201	Ceramic, 1000PF $\pm 20\%$
			C119	DK1710301	Ceramic, 0.01 $\mu$ F $\pm 20\%$
			C120	DD1620003	Ceramic, 20PF $\pm 10\%$
G	120200640	String Assembly	C121	DD1210006	Ceramic, 10PF $\pm 10\%$
0813	120225801	Hook	C122	DD1615003	Ceramic, 15PF $\pm 10\%$
0814	72080802A	String	C123	DD1615003	Ceramic, 15PF $\pm 10\%$
			C124	DK1710301	Ceramic, 0.01 $\mu$ F $\pm 20\%$
H	285010341	Pointer Assembly	C125	DK1810301	Ceramic, 0.01 $\mu$ F +100%, -0%
0823	281810301	Pointer	C126	DK1810301	Ceramic, 0.01 $\mu$ F +100%, -0%
0824	285010301	Pointer	C127	DK1710301	Ceramic, 0.01 $\mu$ F $\pm 20\%$
0825	281805301	Cover	C129	DK1710301	Ceramic, 0.01 $\mu$ F $\pm 20\%$
M003	IN1008030	Lamp	C130	DK1710301	Ceramic, 0.01 $\mu$ F $\pm 20\%$
			C131	DK1710301	Ceramic, 0.01 $\mu$ F $\pm 20\%$
					<b>P100-COILS &amp; TRANSFORMER</b>
2102	51100306S	B.H.M. Screw x 4	L101	LA1027801	Ant. Coil
			L102	LA1027802	RF Coil
			L103	LA1027803	RF Coil
			L104	LA1027804	RF Coil
2119	64000400R	RG Ring E	L105	LO1202604	OSC Coil
			L106	LI1001601	IFT
2030	71101669Q	Spring x 2			<b>P100-SEMICONDUCTORS</b>
			H101	HF200191A	FET, 2SK19Y
			H102	HF200191A	FET, 2SK19Y
			H103	HT305351B	Transistor, 2SC535B
P100	YD2818001	<b>FM-RF CIRCUIT BOARD-P100</b>			
	ZZ2818001	P.W. Board, FM RF(Print Only)			
		P.W. Board Assembly			

REF. DESIG.	PART NO.	DESCRIPTION
<b>P100-MISCELLANEOUS</b>		
J101 } J106	YP1000094	Plug
2011	281810903	Shield
2012	281810904	Shield x 2
2013	281810905	Shield
2002	281810950	Shield K
2016	281810908	Shield
2017	114325901	Bush x 2
2018	114325902	Bush x 2
2021	281805102	Guide
2106	51570306B	P.H. Tapt Screw x 4
2111	51100304A	B.H.M. Screw x 2
2112	51040308A	F.H.M. Screw x 2
2113	51100304E	B.H.M. Screw x 3
2114	51060305E	P.H.M. Screw x 3
2121	54040402N	Spring Washer
2122	53110403E	Hexagon Nut
2007	289016006	Bracket, FM Front End
2008	281816008	Bracket, FM Front End
2009	281811201	Shaft
C001	CA0330002	Variable Cap., AM 3 Gang
0836	138200503	Clamper
2032	289215901	Drum, Tuning
2034	71101569M	Spring
2026	281805850	Gear K x 2, Tuning
2117	51650304D	Set Screw HP x 4
<b>AM CIRCUIT BOARD-P150</b>		
P150	YD2890001 ZZ2889101	P.W. Board, AM(Print Only) P.W. Board Assembly
<b>P150-RESISTORS</b>		
All resistors are $\pm 5\%$ and $\frac{1}{4}W$ , unless otherwise indicated.		
R151	RT0515114	150 $\Omega$
R152	RA0103025	Trimming, 10K $\Omega$ (B)
R153	RT0556214	5.6K $\Omega$
R154	RT0510314	10K $\Omega$
R155	RT0510314	10K $\Omega$
R156	RT0510214	1K $\Omega$
R157	RT0530114	300 $\Omega$
R158	RT0533314	33K $\Omega$
R159	RT0510414	100K $\Omega$
R160	RT0527214	2.7K $\Omega$
R161	RT0527214	2.7K $\Omega$
R162	RT0510414	100K $\Omega$
R163	RT0510114	100 $\Omega$
R164	RT0556214	5.6K $\Omega$
R165	RT0510114	100 $\Omega$

REF. DESIG.	PART NO.	DESCRIPTION
R166	RT0510414	100K $\Omega$
R167	RT0512414	120K $\Omega$
R168	RT0515214	1.5K $\Omega$
<b>P150-CAPACITORS</b>		
C151	DK1710301	Ceramic, 0.01 $\mu F \pm 20\%$
C152	DF6545101	Film, 450PF $\pm 5\%$
C153	DF1747305	Film, 0.047 $\mu F \pm 20\%$
C154	DK1840302	Ceramic, 0.04 $\mu F +80\%$ , -20%
C155	EA1070169	Electroly, 100 $\mu F$ , 16V
C157	DK1710301	Ceramic, 0.01 $\mu F \pm 20\%$
C158	DK1710301	Ceramic, 0.01 $\mu F \pm 20\%$
C159	DD1620001	Ceramic, 20PF $\pm 10\%$
C160	EA4750359	Electroly, 4.7 $\mu F$ , 35V
C161	EA3350509	Electroly, 3.3 $\mu F$ , 50V
C162	DK1710201	Ceramic, 1000PF $\pm 20\%$
C163	DF1710301	Film, 0.01 $\mu F \pm 20\%$
C164	DK1710301	Ceramic, 0.01 $\mu F \pm 20\%$
C165	DF1610405	Film, 0.1 $\mu F \pm 10\%$
C166	DK1840302	Ceramic, 0.04 $\mu F +80\%$ , -20%
C167	EA1070169	Electroly, 100 $\mu F$ , 16V
C168	EA1050509	Electroly, 1 $\mu F$ , 50V
C169	DK1710301	Ceramic, 0.01 $\mu F \pm 20\%$
C170	EA1050509	Electroly, 1 $\mu F$ , 50V
<b>P150-SEMICONDUCTORS</b>		
H151	HC1000301	IC, HA1151
H152	HT306441C	Transistor, 2SC644 (T)
<b>P150-COILS &amp; TRANSFORMERS</b>		
L151	LA1001017	RF Coil
L152	LO1001048	OSC Coil
L153	LI1028002	I.F.T.
L154	LI1001064	I.F.T.
L155	LC1332002	Choke Coil, 3.3 $\mu H$
L156	LC1332002	Choke Coil, 3.3 $\mu H$
<b>P150-MISCELLANEOUS</b>		
J151 } J161	YP1000113	Plug
<b>FM-I.F. CIRCUIT BOARD-P200</b>		
P200	YD2892014 ZZ2904114	P.W. Board, FM IF(Print Only) P.W. Board Assembly
<b>P200-RESISTORS</b>		
All resistors are $\pm 5\%$ and $\frac{1}{4}W$ , unless otherwise indicated.		
R201	RT0515114	150 $\Omega$
R202	RT0582214	8.2K $\Omega$
R203	RT0518314	18K $\Omega$
R204	RT0510214	1K $\Omega$
R205	RT0533114	330 $\Omega$
R207	RT0547014	47 $\Omega$
R208	RT0533214	3.3K $\Omega$
R209	RT0515214	1.5K $\Omega$
R210	RT0515114	150 $\Omega$
R211	RA0101001	Trimming, 100 $\Omega$ (B)
R212	RT0556114	560 $\Omega$
R213	RT0533114	330 $\Omega$
R215	RT0547014	47 $\Omega$
R216	RT0533214	3.3K $\Omega$
R217	RT0515214	1.5K $\Omega$
R218	RT0515114	150 $\Omega$

REF. DESIG.	PART NO.	DESCRIPTION
R219	RT0556114	560Ω
R220	RT0515114	150Ω
R221	RT0518114	180Ω
R223	RT0547314	47KΩ
R224	RT0547014	47Ω
R225	RT0515214	1.5KΩ
R226	RT0533214	3.3KΩ
R227	RT0515114	150Ω
R228	RT0556114	560Ω
R229	RT0522114	220Ω
R230	RT0515114	150Ω
R231	RT0515114	150Ω
R232	RT0510414	100KΩ
R234	RT0568314	68KΩ
R235	RT0547014	47Ω
R236	RT0582114	820Ω
R237	RT0556314	56KΩ
R238	RT0582114	820Ω
R239	RT0515214	1.5KΩ
R240	RT0533214	3.3KΩ
R241	RT0515114	150Ω
R242	RT0510214	1KΩ
R243	RT0510214	1KΩ
R244	RT0515114	150Ω
R246	RT0568314	68KΩ
R248	RT0547014	47Ω
R249	RT0515114	150Ω
R250	RT0510414	100KΩ
R251	RT0582214	8.2KΩ
R252	RT0515314	15KΩ
R253	RT0510214	1KΩ
R254	RT0510214	1KΩ
R255	RT0515114	150Ω
R257	RT0539314	39KΩ
R258	RT0522314	22KΩ
R259	RT0582114	820Ω
R260	RT0510414	100KΩ
R261	RT0515114	150Ω
R262	RT0582214	8.2KΩ
R263	RT0515314	15KΩ
R264	RT0510214	1KΩ
R265	RT0510214	1KΩ
R266	RT0510114	100Ω
R267	RT0533114	330Ω
R268	RT0515114	150Ω
R269	RT0510414	100KΩ
R270	RT0582214	8.2KΩ
R271	RT0515314	15KΩ
R272	RT0510214	1KΩ
R273	RT0510114	100Ω
R274	RT0515314	15KΩ
R275	RT0582114	820Ω
R276	RT0582114	820Ω
R277	RT0582114	820Ω
R278	RT0568214	6.8KΩ
R279	RT0568214	6.8KΩ
R280	RT0510114	100Ω
R281	RT0556314	56KΩ
R282	RT0522314	22KΩ
R283	RT0510114	100Ω
R284	RT0510414	100KΩ
R285	RT0518414	180KΩ

REF. DESIG.	PART NO.	DESCRIPTION
R286	RT0510114	100Ω
R287	RT0522214	2.2KΩ
R288	RT0510114	100Ω
R289	RT0510114	100Ω
R290	RT0512114	120Ω
R291	RT0582214	8.2KΩ
R292	RT0518314	18KΩ
R293	RT0522214	2.2KΩ
R294	RT0510414	100KΩ
R296	RT0533314	33KΩ
<b>P200-CAPACITORS</b>		
C201	DK1810301	Ceramic, 0.01μF +80%, -20%
C202	DK1810301	Ceramic, 0.01μF +80%, -20%
C203	DK1840302	Ceramic, 0.04μF +80%, -20%
C204	EA1060169	Electroly, 10μF, 16V
C205	EA1060169	Electroly, 10μF, 16V
C206	DK1840302	Ceramic, 0.04μF +80%, -20%
C207	DK1810301	Ceramic, 0.01μF +80%, -20%
C208	EA1060169	Electroly, 10μF, 16V
C209	DK1840302	Ceramic, 0.04μF +80%, -20%
C210	DK1810301	Ceramic, 0.01μF +80%, -20%
C211	DD1540001	Ceramic, 40PF ± 5%
C213	DK1810301	Ceramic, 0.01μF +80%, -20%
C214	DD1540001	Ceramic, 40PF ± 5%
C215	DK1810301	Ceramic, 0.04μF +80%, -20%
C217	DK1840302	Ceramic, 0.04μF +80%, -20%
C218	EA1060169	Electroly, 10μF, 16V
C219	EA1060169	Electroly, 10μF, 16V
C220	DK1840302	Ceramic, 0.04μF +80%, -20%
C221	DK1810301	Ceramic, 0.01μF +80%, -20%
C222	DK1810301	Ceramic, 0.01μF +80%, -20%
C223	DD1540001	Ceramic, 40PF ± 5%
C225	DK1810301	Ceramic, 0.01μF +80%, -20%
C226	DK1810301	Ceramic, 0.01μF +80%, -20%
C227	DK1810301	Ceramic, 0.01μF +80%, -20%
C228	DD1540001	Ceramic, 40PF ± 5%
C229	EA1060169	Electroly, 10μF, 16V
C230	DK1840302	Ceramic, 0.04μF +80%, -20%
C232	DK1810301	Ceramic, 0.01μF +80%, -20%
C233	DD1540001	Ceramic, 40PF ± 5%
C234	DK1810301	Ceramic, 0.01μF +80%, -20%
C235	DK1810301	Ceramic, 0.01μF +80%, -20%
C236	DK1810301	Ceramic, 0.01μF +80%, -20%
C237	DK1810301	Ceramic, 0.01μF +80%, -20%
C238	DK1840302	Ceramic, 0.04μF +80%, -20%
C239	DD1620101	Ceramic, 200PF ± 10%
C240	DD1620101	Ceramic, 200PF ± 10%
C241	DD1620101	Ceramic, 200PF ± 10%
C242	EA1060169	Electroly, 10μF, 16V
C244	EA1060169	Electroly, 10μF, 16V
C245	EA1060169	Electroly, 10μF, 16V
C246	DK1840302	Ceramic, 0.04μF +80%, -20%
C247	DK1840302	Ceramic, 0.04μF +80%, -20%
C248	EA1060169	Electroly, 10μF, 16V
C249	EA1070169	Electroly, 100μF, 16V
C250	EA1060169	Electroly, 10μF, 16V
C251	DK1810301	Ceramic, 0.01μF +80%, -20%
C252	DD1540001	Ceramic, 40PF ± 5%
C253	DK1840302	Ceramic, 0.04μF +80%, -20%
C254	DD1540001	Ceramic, 40PF ± 5%
C255	DD1620101	Ceramic, 200PF ± 10%

REF. DESIG.	PART NO.	DESCRIPTION
C256	EV1050352	Electroly, 1 $\mu$ F $\pm$ 20%, 35V
C257	DD1620101	Ceramic, 200PF $\pm$ 10%
C258	DK1810301	Ceramic, 0.01 $\mu$ F +80%, -20%
C259	DK1840302	Ceramic, 0.04 $\mu$ F +80%, -20%
<b>P200-CERAMIC FILTERS</b>		
F201	FF1107003	SFA 10.7MC
F202	FF1107003	SFA 10.7MC
F203	FF1107003	SFA 10.7MC
F204	FF1107003	SFA 10.7MC
F205	FF1107003	SFA 10.7MC
F206	FF1107003	SFA 10.7MC
F207	FF1107003	SFA 10.7MC
F208	FF1107003	SFA 10.7MC
<b>P200-COIL &amp; TRANSFORMER</b>		
L201	LI1401623	I.F.T., FM DET.
L202	LC1332002	Choke Coil, 3.3 $\mu$ H
<b>P200-SEMICONDUCTORS</b>		
H201	HT308291C	Transistor, 2SC829C
H202	HT308291C	Transistor, 2SC829C
H203	HT308291C	Transistor, 2SC829C
H204	HT308291C	Transistor, 2SC829C
H205	HT308291C	Transistor, 2SC829C
H206	HT308291C	Transistor, 2SC829C
H207	HT308291C	Transistor, 2SC829C
H208	HT308291C	Transistor, 2SC829C
H209	HT308291C	Transistor, 2SC829C
H210	HT306441B	Transistor, 2SC644S
H211	HD2000121	Diode, 1S2473C
H212	HD2000121	Diode, 1S2473C
H213	HD2000121	Diode, 1S2473C
H214	HD2000121	Diode, 1S2473C
H215	HD2000121	Diode, 1S2473C
H216	HD2000121	Diode, 1S2473C
H217	HD2000121	Diode, 1S2473C
H218	HD2000121	Diode, 1S2473C
H219	HD1000302	Diode, 20A90M
H220	HD1000302	Diode, 20A90M
H221	HD1000105	Diode, 1N60
H222	HD1000105	Diode, 1N60
H223	HD1000105	Diode, 1N60
H224	HD1000105	Diode, 1N60
H225	HD1000105	Diode, 1N60
H226	HD1000105	Diode, 1N60
H227	HD1000105	Diode, 1N60
H228	HD1000105	Diode, 1N60
H229	HD1000105	Diode, 1N60
H230	HD1000105	Diode, 1N60
H231	HD1000105	Diode, 1N60
H232	HD1000105	Diode, 1N60
H233	HD1000302	Diode, 20A90M
<b>P200-MISCELLANEOUS</b>		
J201	YP1000113	Plug
J211		
G201	BF2230006	Printed Comp., 1K $\Omega$ + 0.022 $\mu$ F
G202	BF1020002	Printed Comp., 100K $\Omega$ + 1000PF
G203	BF2010004	Printed Comp., 27K $\Omega$ + 200PF
G204	BF2010004	Printed Comp., 27K $\Omega$ + 200PF
G205	BF2010004	Printed Comp., 27K $\Omega$ + 200PF
G206	BF2010004	Printed Comp., 27K $\Omega$ + 200PF

REF. DESIG.	PART NO.	DESCRIPTION
G207	BF2010004	Printed Comp., 27K $\Omega$ + 200PF
<b>MPX CIRCUIT BOARD-P300</b>		
P300	YD2890003	P.W. Board, MPX (Print Only)
	ZZ2904103	P.W. Board Assembly
<b>P300-RESISTORS</b>		
All resistors are $\pm$ 5% and $\frac{1}{4}$ W, unless otherwise indicated.		
R301	RA0202011	Trimming, 2K $\Omega$ (B)
R302	RT0522414	220K $\Omega$
R303	RT0556314	56K $\Omega$
R304	RT0568314	68K $\Omega$
R305	RT0510114	100 $\Omega$
R306	RT0518414	180K $\Omega$
R307	RT0522414	220K $\Omega$
R308	RT0512414	120K $\Omega$
R309	RT0510414	100K $\Omega$
R310	RT0568214	6.8K $\Omega$
R311	RA0502020	Trimming, 5K $\Omega$ (B)
R312	RT0516314	16K $\Omega$
R313	RT0510214	1K $\Omega$
R314	RT0522414	220K $\Omega$
R315	RT0510214	1K $\Omega$
R316	RT0510214	1K $\Omega$
R317	RT0539214	3.9K $\Omega$
R318	RT0539214	3.9K $\Omega$
R319	RT0522414	220K $\Omega$
R320	RT0522314	22K $\Omega$
R321	RT0510114	100 $\Omega$
R322	RT0510014	10 $\Omega$
R323	RT0522414	220K $\Omega$
R324	RT0522414	220K $\Omega$
R325	RT0530314	30K $\Omega$
R326	RT0530314	30K $\Omega$
R327	RT0510414	100K $\Omega$
R328	RT0510414	100K $\Omega$
R329	RT0510514	1M $\Omega$
R330	RT0510514	1M $\Omega$
R331	RT0510214	1K $\Omega$
R332	RT0510214	1K $\Omega$
R333	RT0522314	22K $\Omega$
R334	RT0522314	22K $\Omega$
R335	RT0510114	100 $\Omega$
R336	RT0510114	100 $\Omega$
R337	RT0582214	8.2K $\Omega$
R338	RT0582214	8.2K $\Omega$
R339	RT0547114	470 $\Omega$
R340	RT0547114	470 $\Omega$
R341	RT0522414	220K $\Omega$
R342	RT0522414	220K $\Omega$
R343	RT0539214	3.9K $\Omega$
R344	RT0556414	560K $\Omega$
R345	RT0515314	15K $\Omega$
R346	RT0512414	120K $\Omega$
R347	RT0510114	100 $\Omega$
R348	RT0522414	220K $\Omega$
R349	RT0556214	5.6K $\Omega$
R350	RT0510314	10K $\Omega$
R351	RT0510114	100 $\Omega$
R352	RT0533314	33K $\Omega$
R353	RT0510114	100 $\Omega$

REF. DESIG.	PART NO.	DESCRIPTION	
R354	RT0510414	100K $\Omega$	
R355	RT0527314	27K $\Omega$	
R356	RT0510414	100K $\Omega$	
R357	RT0510214	1K $\Omega$	
R358	RT0510114	100 $\Omega$	
R359	RT0527314	27K $\Omega$	
R360	RT0533314	33K $\Omega$	
R361	RT0510414	100K $\Omega$	
R362	RA0104018	Trimming, 100K $\Omega$ (B)	
R363	RA0103025	Trimming, 10K $\Omega$ (B)	
R364	RT0522214	2.2K $\Omega$	
R365	RT0510114	100 $\Omega$	
R366	RT0510314	10K $\Omega$	
R367	RT0510114	100 $\Omega$	
R368	RT0527414	270K $\Omega$	
R369	RT0510314	10K $\Omega$	
R370	RT0512314	12K $\Omega$	
R371	RT0522114	220 $\Omega$	
R373	RT0533314	33K $\Omega$	
R374	RA0103025	Trimming, 10K $\Omega$ (B)	
R375	RT0510114	100 $\Omega$	
R376	RT0510414	100K $\Omega$	
R377	RT0510414	100K $\Omega$	
R378	RT0556214	5.6K $\Omega$	
R379	RT0533214	3.3K $\Omega$	
<b>P300-CAPACITORS</b>			
C301	DF1622205	Film, 2200PF $\pm$ 10%	
C302	EA3360109	Electroly, 33 $\mu$ F, 10V	
C303	DF1722305	Film, 0.022 $\mu$ F $\pm$ 20%	
C304	EA1060169	Electroly, 10 $\mu$ F, 16V	
C305	DF5547101	Film, 470PF $\pm$ 5%	
C306	EA1060169	Electroly, 10 $\mu$ F, 16V	
C307	EQ4740501	Electroly, 0.47 $\mu$ F $\pm$ 20%,	50V
C308	EQ2240501	Electroly, 0.22 $\mu$ F $\pm$ 20%,	50V
C309	EQ2240501	Electroly, 0.22 $\mu$ F $\pm$ 20%,	50V
C310	DF1747301	Film, 0.047 $\mu$ F $\pm$ 20%	
C311	DF1515205	Film, 1500PF $\pm$ 5%	
C312	DF1515205	Film, 1500PF $\pm$ 5%	
C313	DD1536101	Ceramic, 360PF $\pm$ 5%	
C314	DD1536101	Ceramic, 360PF $\pm$ 5%	
C315	DF1533205	Film, 3300PF $\pm$ 5%	
C316	DF1533205	Film, 3300PF $\pm$ 5%	
C317	DF1515205	Film, 1500PF $\pm$ 5%	
C318	DF1515205	Film, 1500PF $\pm$ 5%	
C319	DF1522205	Film, 2200PF $\pm$ 5%	
C320	DF1522205	Film, 2200PF $\pm$ 5%	
C321	DF1510205	Film, 1000PF $\pm$ 5%	
C322	DF1510205	Film, 1000PF $\pm$ 5%	
C323	EV2240351	Electroly, 0.22 $\mu$ F $\pm$ 20%,	35V
C324	EV2240351	Electroly, 0.22 $\mu$ F $\pm$ 20%,	35V
C325	EV1050352	Electroly, 1 $\mu$ F $\pm$ 20%,	35V
C326	EV1050352	Electroly, 1 $\mu$ F $\pm$ 20%,	35V
C327	EA2270259	Electroly, 220 $\mu$ F, 25V	
C328	EA2270169	Electroly, 220 $\mu$ F, 16V	
C329	EA1060169	Electroly, 10 $\mu$ F, 16V	
C330	DK1840302	Ceramic, 0.04 $\mu$ F +80%, -20%	
C331	EA1050509	Electroly, 1 $\mu$ F, 50V	
C332	EA1060169	Electroly, 10 $\mu$ F, 16V	
C333	DD1210001	Ceramic, 10PF $\pm$ 10%	
C334	DF1668301	Film, 0.068 $\mu$ F $\pm$ 10%	
C335	DF1740301	Film, 0.04 $\mu$ F $\pm$ 20%	
C336	DK1810402	Ceramic, 0.1 $\mu$ F +80%, -20%	

REF. DESIG.	PART NO.	DESCRIPTION	
C337	EA4750359	Electroly, 4.7 $\mu$ F, 35V	
C338	EA1050509	Electroly, 1 $\mu$ F, 50V	
C342	EA1060169	Electroly, 10 $\mu$ F, 16V	
C343	DF1710402	Film, 0.1 $\mu$ F $\pm$ 20%	
C344	DK1820302	Ceramic, 0.02 $\mu$ F +80%, -20%	
<b>P300-SEMICONDUCTORS</b>			
H301	HF200301C	FET, 2SK30Y	
H302	HT308281D	Transistor, 2SC828S	
H303	HT308281D	Transistor, 2SC828S	
H304	HT307322A	Transistor, 2SC732B or G	
H305	HT307322A	Transistor, 2SC732B or G	
H306	HT104942A	Transistor, 2SA494G or Y	
H307	HT104942A	Transistor, 2SA494G or Y	
H308	HT308281D	Transistor, 2SC828S	
H309	HT308281D	Transistor, 2SC828S	
H310	HT308281D	Transistor, 2SC828S	
H311	HT308281D	Transistor, 2SC828S	
H312	HF200300A	FET, 2SK30A	
H313	HT308281D	Transistor, 2SC828S	
H314	HT308281D	Transistor, 2SC828S	
H315	HT308281D	Transistor, 2SC828S	
H316	HT308281D	Transistor, 2SC828S	
H317	HT308281D	Transistor, 2SC828S	
H318	HD1000105	Diode, 1N60	
H319	HD1000105	Diode, 1N60	
H321	HC1000401	I.C., HA1156	
<b>P300-COILS</b>			
L301	LS1029004	MPX Coil, 56mH	
L302	LS1029004	MPX Coil, 56mH	
L303	LS1029005	MPX Coil, 43mH	
L304	LS1029005	MPX Coil, 43mH	
L305	LC2105001	Choke Coil, 1mH	
<b>P300-MISCELLANEOUS</b>			
J301			
J322	YP1000113	Plug	
P400	YD2892008 ZZ2892008	PHONO AMP. CIRCUIT BOARD-P400 P.W. Board, Phono Amp (Print Only) P.W. Board Assembly	
<b>P400-RESISTORS</b>			
All resistors are $\pm$ 5% and $\frac{1}{4}$ W, unless otherwise indicated.			
R401	RT0556314	56K $\Omega$	
R402	RT0556314	56K $\Omega$	
R403	RT0547114	470 $\Omega$	
R404	RT0547114	470 $\Omega$	
R405	RN0533314	33K $\Omega$	
R406	RN0510514	1M $\Omega$	
R407	RN0510514	1M $\Omega$	
R408	RA0104015	Trimming, 100K $\Omega$ (B)	
R409	RA0104015	Trimming, 100K $\Omega$ (B)	
R410	RN0527314	27K $\Omega$	
R411	RN0527314	27K $\Omega$	
R412	RT0562114	620 $\Omega$	
R413	RT0562114	620 $\Omega$	
R414	RT0522514	2.2M $\Omega$	
R415	RT0522514	2.2M $\Omega$	
R416	RN0522514	2.2M $\Omega$	
R417	RN0522514	2.2M $\Omega$	

REF. DESIG.	PART NO.	DESCRIPTION
R418	RN0527414	270K $\Omega$
R419	RN0527414	270K $\Omega$
R420	RT0547314	47K $\Omega$
R421	RT0547314	47K $\Omega$
R422	RT0522214	2.2K $\Omega$
R423	RT0522214	2.2K $\Omega$
R424	RN0568414	680K $\Omega$
R425	RN0568414	680K $\Omega$
R426	RN0510414	100K $\Omega$
R427	RN0510414	100K $\Omega$
R428	RN0547314	47K $\Omega$
R429	RN0547314	47K $\Omega$
R430	RT0547014	47 $\Omega$
R431	RT0547014	47 $\Omega$
R432	RN0533214	3.3K $\Omega$
R433	RN0533214	3.3K $\Omega$
R434	RT0510114	100 $\Omega$
R435	RT0547014	47 $\Omega$
R436	RT0547014	47 $\Omega$
<b>P400-CAPACITORS</b>		
C401	EV1050256	Electroly, 1 $\mu$ F $\pm$ 20%, 25V
C402	EV1050256	Electroly, 1 $\mu$ F $\pm$ 20%, 25V
C403	EE4760163	Electroly, 47 $\mu$ F $\pm$ 20%, 16V
C404	EE4760163	Electroly, 47 $\mu$ F $\pm$ 20%, 16V
C405	DD1540004	Ceramic, 40PF $\pm$ 5%, 50V, NPO
C406	DD1540004	Ceramic, 40PF $\pm$ 5%, 50V, NPO
C407	DD1104001	Ceramic, 4PF $\pm$ 0.5PF
C408	DD1104001	Ceramic, 4PF $\pm$ 0.5PF
C409	DF6556201	Film, 5600PF $\pm$ 5%
C410	DF6556201	Film, 5600PF $\pm$ 5%
C411	DF6516201	Film, 1600PF $\pm$ 5%
C412	DF6516201	Film, 1600PF $\pm$ 5%
C413	ED1070351	Electroly, 100 $\mu$ F, 35V
C414	DF1710551	Film, 1 $\mu$ F $\pm$ 20%, 250V
C415	DF1710551	Film, 1 $\mu$ F $\pm$ 20%, 250V
C416	DD1650001	Ceramic, 50PF $\pm$ 10%
C417	DD1650001	Ceramic, 50PF $\pm$ 10%
<b>P400-SEMICONDUCTORS</b>		
H401	HT313441E	Transistor, 2SC1344E
H402	HT313441E	Transistor, 2SC1344E
H403	HT313442A	Transistor, 2SC1344D or E
H404	HT313442A	Transistor, 2SC1344D or E
H405	HT304580R	Transistor, 2SC458L, G or B
H406	HT304580R	Transistor, 2SC458L, G or B
H407	HD2000121	Diode, 1S-2473C (Ye)
H408	HD2000121	Diode, 1S-2473C (Ye)
H409	HV0000206	Varistor, VD1212
<b>P400-MISCELLANEOUS</b>		
J401	YP1000113	Plug
J408		
<b>VARI-MATRIX CIRCUIT BOARD-P500</b>		
P500	YD2889004	P.W. Board, Vari-Matrix(Print Only)
	ZZ2889004	P.W. Board Assembly
<b>P500-RESISTORS</b>		
All resistors are $\pm$ 5% and $\frac{1}{4}$ W.		
R501	RT0515414	150K $\Omega$
R502	RT0515414	150K $\Omega$
R503	RT0556314	56K $\Omega$

REF. DESIG.	PART NO.	DESCRIPTION
R504	RT0556314	56K $\Omega$
R505	RT0522414	220K $\Omega$
R506	RT0522414	220K $\Omega$
R507	RT0533414	330K $\Omega$
R508	RT0533414	330K $\Omega$
R509	RT0556214	5.6K $\Omega$
R510	RT0556214	5.6K $\Omega$
R511	RT0556214	5.6K $\Omega$
R512	RT0556214	5.6K $\Omega$
R513	RT0568214	6.8K $\Omega$
R514	RT0568214	6.8K $\Omega$
R515	RT0568214	6.8K $\Omega$
R516	RT0568214	6.8K $\Omega$
R517	RT0547314	47K $\Omega$
R518	RT0547314	47K $\Omega$
R519	RT0547314	47K $\Omega$
R520	RT0547314	47K $\Omega$
R521	RT0547414	470K $\Omega$
R522	RT0547414	470K $\Omega$
R523	RT0568314	68K $\Omega$
R524	RT0568314	68K $\Omega$
R525	RT0512514	1.2M $\Omega$
R526	RT0512514	1.2M $\Omega$
R527	RT0510214	1K $\Omega$
R528	RT0510214	1K $\Omega$
R529	RT0522314	22K $\Omega$
R530	RT0522314	22K $\Omega$
R531	RT0515314	15K $\Omega$
R532	RT0515314	15K $\Omega$
R533	RT0510414	100K $\Omega$
R534	RT0510414	100K $\Omega$
R535	RT0510214	1K $\Omega$
R536	RT0510214	1K $\Omega$
R537	RT0522114	220 $\Omega$
J501	YP1000113	Plug
J513		
<b>P500-MISCELLANEOUS</b>		
<b>P500-CAPACITORS</b>		
C501	EE4740501	Electroly, 0.47 $\mu$ F $\pm$ 20%, 50V
C502	EE4740501	Electroly, 0.47 $\mu$ F $\pm$ 20%, 50V
C503	EE3350501	Electroly, 3.3 $\mu$ F $\pm$ 20%, 50V
C504	EE3350501	Electroly, 3.3 $\mu$ F $\pm$ 20%, 50V
C505	EE3350501	Electroly, 3.3 $\mu$ F $\pm$ 20%, 50V
C506	EE3350501	Electroly, 3.3 $\mu$ F $\pm$ 20%, 50V
C507	DF1647305	Film, 0.047 $\mu$ F $\pm$ 10%, 50V
C508	DF1647305	Film, 0.047 $\mu$ F $\pm$ 10%, 50V
C509	DF1647305	Film, 0.047 $\mu$ F $\pm$ 10%, 50V
C510	DF1647305	Film, 0.047 $\mu$ F $\pm$ 10%, 50V
C511	EE3350501	Electroly, 3.3 $\mu$ F $\pm$ 20%, 50V
C512	EE3350501	Electroly, 3.3 $\mu$ F $\pm$ 20%, 50V
C513	EE3350501	Electroly, 3.3 $\mu$ F $\pm$ 20%, 50V
C514	EE3350501	Electroly, 3.3 $\mu$ F $\pm$ 20%, 50V
C515	EA2260359	Electroly, 22 $\mu$ F +100%, -10%, 35V
C516	EA2260359	Electroly, 22 $\mu$ F +100%, -10%, 35V
C517	DD1650101	Ceramic, 500PF $\pm$ 10%, 50V
C518	DD1650101	Ceramic, 500PF $\pm$ 10%, 50V
C519	EA1070359	Electroly, 100 $\mu$ F +100%, -10%, 35V
H501	HT313272A	P500-TRANSISTORS 2SC1327S or T
H502	HT313272A	2SC1327S or T

REF. DESIG.	PART NO.	DESCRIPTION
H503	HT313272A	2SC1327S or T
H504	HT313272A	2SC1327S or T
H505	HT106401L	2SA640L
H506	HT106401L	2SA640L
1910	51100304S	<b>P500-MISCELLANEOUS</b> B.H.M. Screw x 8
PV01	YD2892009	<b>GENERAL MISCELLANEOUS</b> P.W. Board, Dolby Terminal
1903	289216007	Bracket
1904	289212001	Insulator
1906	289210106	Insulator x 4
1907	289210107	Insulator x 4
1912	51100305A	B.H.M. Screw x 2
P600	YD2886008 ZZ2904108	<b>DOLBY CIRCUIT BOARD-P600</b> P.W. Board, Dolby x 2 (Print Only) P.W. Board Assembly x 2
		<b>P600-RESISTORS</b> All resistors are $\pm 5\%$ and $\frac{1}{4}W$ , unless otherwise indicated.
R601	RT0547414	470K $\Omega$ x 2
R602	RT0547414	470K $\Omega$ x 2
R603	RT0510414	100K $\Omega$ x 2
R604	RT0510414	100K $\Omega$ x 2
R605	RT0533214	3.3K $\Omega$ x 2
R606	RT0533214	3.3K $\Omega$ x 2
R607	RT0510214	1K $\Omega$ x 2
R608	RT0510214	1K $\Omega$ x 2
R609	RT0539314	39K $\Omega$ x 2
R610	RT0539314	39K $\Omega$ x 2
R611	RT0568214	6.8K $\Omega$ x 2
R612	RT0568214	6.8K $\Omega$ x 2
R613	RT0510114	100 $\Omega$ x 2
R614	RT0510114	100 $\Omega$ x 2
R615	RT0522214	2.2K $\Omega$ x 2
R616	RT0522214	2.2K $\Omega$ x 2
R617	RT0512114	120 $\Omega$ x 2
R618	RT0512114	120 $\Omega$ x 2
R619	RT0556114	560 $\Omega$ x 2
R620	RT0556114	560 $\Omega$ x 2
R621	RT0533314	33K $\Omega$ x 2
R622	RT0533314	33K $\Omega$ x 2
R623	RT0515414	150K $\Omega$ x 2
R624	RT0515414	150K $\Omega$ x 2
R625	RT0518414	180K $\Omega$ x 2
R626	RT0518414	180K $\Omega$ x 2
R627	RT0527314	27K $\Omega$ x 2
R628	RT0527314	27K $\Omega$ x 2
R629	RT0582214	8.2K $\Omega$ x 2
R630	RT0582214	8.2K $\Omega$ x 2
R631	RT0515414	150K $\Omega$ x 2
R632	RT0515414	150K $\Omega$ x 2
R633	RT0522314	22K $\Omega$ x 2
R634	RT0522314	22K $\Omega$ x 2
R635	RT0527214	2.7K $\Omega$ x 2
R636	RT0527214	2.7K $\Omega$ x 2
R637	RT0533314	33K $\Omega$ x 2
R638	RT0533314	33K $\Omega$ x 2

REF. DESIG.	PART NO.	DESCRIPTION
R639	RT0547314	47K $\Omega$ x 2
R640	RT0547314	47K $\Omega$ x 2
R643	RT0527414	270K $\Omega$ x 2
R644	RT0527414	270K $\Omega$ x 2
R645	RT0547314	47K $\Omega$ x 2
R646	RT0547314	47K $\Omega$ x 2
R647	RT0533214	3.3K $\Omega$ x 2
R648	RT0533214	3.3K $\Omega$ x 2
R649	RT0515214	1.5K $\Omega$ x 2
R650	RT0515214	1.5K $\Omega$ x 2
R651	RT0522314	22K $\Omega$ x 2
R652	RT0522314	22K $\Omega$ x 2
R653	RA0103022	Variable, 10K $\Omega$ (B) x 2
R654	RA0103022	Variable, 10K $\Omega$ (B) x 2
R655	RT0527214	2.7K $\Omega$ x 2
R656	RT0527214	2.7K $\Omega$ x 2
R657	RT0568414	680K $\Omega$ x 2
R658	RT0568414	680K $\Omega$ x 2
R659	RA0102020	Variable, 1K $\Omega$ (B) x 2
R660	RA0102020	Variable, 1K $\Omega$ (B) x 2
R661	RT0515314	15K $\Omega$ x 2
R662	RT0515314	15K $\Omega$ x 2
R663	RT0582214	8.2K $\Omega$ x 2
R664	RT0582214	8.2K $\Omega$ x 2
R665	RT0510314	10K $\Omega$ x 2
R666	RT0510314	10K $\Omega$ x 2
R667	RT0582214	8.2K $\Omega$ x 2
R668	RT0582214	8.2K $\Omega$ x 2
R669	RT0582214	8.2K $\Omega$ x 2
R670	RT0582214	8.2K $\Omega$ x 2
R671	RT0533314	33K $\Omega$ x 2
R672	RT0533314	33K $\Omega$ x 2
R673	RT0512414	120K $\Omega$ x 2
R674	RT0512414	120K $\Omega$ x 2
R675	RT0547314	47K $\Omega$ x 2
R676	RT0547314	47K $\Omega$ x 2
R677	RT0527214	2.7K $\Omega$ x 2
R678	RT0527214	2.7K $\Omega$ x 2
R679	RT0510214	1K $\Omega$ x 2
R680	RT0510214	1K $\Omega$ x 2
R681	RT0533014	33 $\Omega$ x 2
R682	RT0533014	33 $\Omega$ x 2
R683	RT0547014	47 $\Omega$ x 2
R684	RT0547014	47 $\Omega$ x 2
R685	RT0515314	15K $\Omega$ x 2
R686	RT0515314	15K $\Omega$ x 2
R687	RT0527414	270K $\Omega$ x 2
R688	RT0527414	270K $\Omega$ x 2
R689	RT0527414	270K $\Omega$ x 2
R690	RT0527414	270K $\Omega$ x 2
R691	RT0522414	220K $\Omega$ x 2
R692	RT0522414	220K $\Omega$ x 2
R693	RC1010112	100 $\Omega$ $\pm$ 10%, $\frac{1}{2}W$ x 2
C601	EE3350251	<b>P600-CAPACITORS</b> Electroly, 3.3 $\mu$ F, 25V x 2
C602	EE3350251	Electroly, 3.3 $\mu$ F, 25V x 2
C603	DF6610101	Film, 100PF $\pm$ 10% x 2
C605	DF1510205	Film, 1000PF $\pm$ 5% x 2
C606	DF1618205	Ceramic, 1800PF $\pm$ 20%
C607	EA1060169	Electroly, 10 $\mu$ F, 16V x 2
C608	EA1060169	Electroly, 10 $\mu$ F, 16V x 2

REF. DESIG.	PART NO.	DESCRIPTION
C609	EA1060169	Electroly, 10 $\mu$ F, 16V x 2
C610	EA1060169	Electroly, 10 $\mu$ F, 16V x 2
C611	EA1060169	Electroly, 10 $\mu$ F, 16V x 2
C612	EA1060169	Electroly, 10 $\mu$ F, 16V x 2
C613	EA1060169	Electroly, 10 $\mu$ F, 16V x 2
C614	EA1060169	Electroly, 10 $\mu$ F, 16V x 2
C617	DF1556205	Film, 5600PF $\pm$ 5% x 2
C618	DF1556205	Film, 5600PF $\pm$ 5% x 2
C619	DF1527305	Film, 0.027 $\mu$ F $\pm$ 5% x 2
C620	DF1527305	Film, 0.027 $\mu$ F $\pm$ 5% x 2
C621	DF1547205	Film, 4700PF $\pm$ 5% x 2
C622	DF1547205	Film, 4700PF $\pm$ 5% x 2
C623	EA1060169	Electroly, 10 $\mu$ F, 16V x 2
C624	EA1060169	Electroly, 10 $\mu$ F, 16V x 2
C625	DF1610405	Film, 0.1 $\mu$ F $\pm$ 10% x 2
C626	DF1610405	Film, 0.1 $\mu$ F $\pm$ 10% x 2
C627	EA4760109	Electroly, 47 $\mu$ F, 10V x 2
C628	EA4760109	Electroly, 47 $\mu$ F, 10V x 2
C629	DF1610405	Film, 0.1 $\mu$ F $\pm$ 10% x 2
C630	DF1610405	Film, 0.1 $\mu$ F $\pm$ 10% x 2
C631	EA1060169	Electroly, 10 $\mu$ F, 16V x 2
C632	EA1060169	Electroly, 10 $\mu$ F, 16V x 2
C633	DF1610405	Film, 0.1 $\mu$ F $\pm$ 10% x 2
C634	DF1610405	Film, 0.1 $\mu$ F $\pm$ 10% x 2
C635	EA1060169	Electroly, 10 $\mu$ F, 16V x 2
C636	EA1060169	Electroly, 10 $\mu$ F, 16V x 2
C637	DF1610405	Film, 0.1 $\mu$ F $\pm$ 10% x 2
C638	DF1610405	Film, 0.1 $\mu$ F $\pm$ 10% x 2
C639	DF1633405	Film, 0.33 $\mu$ F $\pm$ 10% x 2
C640	DF1633405	Film, 0.33 $\mu$ F $\pm$ 10% x 2
C641	EA2270259	Electroly, 220 $\mu$ F, 25V x 2
<b>P600-MISCELLANEOUS</b>		
L601	LC2226004	Choke Coil, 22mH x 2
J613	YP1000109	Plug x 2
J614	YP1000109	Plug x 2
J618	YP1000109	Plug x 2
J620	YP1000109	Plug x 2
J621	YP1000109	Plug x 2
<b>P600-SEMICONDUCTORS</b>		
H601	HT313271U	Transistor, 2SC1327U x 2
H602	HT313271U	Transistor, 2SC1327U x 2
H603	HT306441B	Transistor, 2SC644S x 2
H604	HT306441B	Transistor, 2SC644S x 2
H605	HT104941C	Transistor, 2SA494Y x 2
H606	HT104941C	Transistor, 2SA494Y x 2
H607	HT306441B	Transistor, 2SC644S x 2
H608	HT306441B	Transistor, 2SC644S x 2
H609	HT306441B	Transistor, 2SC644S x 2
H610	HT306441B	Transistor, 2SC644S x 2
H611	HF200301E	FET, 2SK30AD x 2
H612	HF200301E	FET, 2SK30AD x 2
H613	HT306441B	Transistor, 2SC644S x 2
H614	HT306441B	Transistor, 2SC644S x 2
H615	HT104941C	Transistor, 2SA494Y x 2
H616	HT104941C	Transistor, 2SA494Y x 2
H617	HT306441B	Transistor, 2SC644S x 2
H618	HT306441B	Transistor, 2SC644S x 2
H621	HD1000105	Diode, 1N60 x 2
H622	HD1000105	Diode, 1N60 x 2
H623	HD2000121	Diode, 1S2473 x 2

REF. DESIG.	PART NO.	DESCRIPTION
H624	HD2000121	Diode, 1S2473 x 2
H625	HD3003109	Diode, WZ-081 x 2
H626	HD2000121	Diode, 1S2473 x 2
H627	HD2000121	Diode, 1S2473 x 2
H628	HD2000121	Diode, 1S2473 x 2
H629	HD2000121	Diode, 1S2473 x 2
<b>GENERAL MISCELLANEOUS</b>		
1820	51100406S	B.H.M. Screw x 4
1821	51100306S	B.H.M. Screw x 4
H001	HT107461B	2SA7460 or Y
H002	HT311151B	2SC11150 or Y
H003	HT107461B	2SA7460 or Y
H004	HT311151B	2SC11150 or Y
H005	HT107461B	2SA7460 or Y
H006	HT311151B	2SC11150 or Y
H007	HT107461B	2SA7460 or Y
H008	HT311151B	2SC11150 or Y
J019		
J026	YJ0500019	Socket, Power TR
1803	289226701	Heat Sink x 2
1805	289016003	Bracket x 4
1807	281810104	Support x 4
1817	282100501	Clamper x 2
1813	289216004	Bracket x 2
1822	51100306S	B.H.M. Screw x 4
1823	51100314E	B.H.M. Screw x 16
1825	51380306T	R.H. Tap Screw x 8
1826	51380306T	R.H. Tap Screw x 4
1827	51570406B	P.H. Tapt Screw x 4
1828	62041760W	Lug x 4
1829	54050400R	T.L. Washer OR x 4
J036	YJ0700007	Socket
J037	YJ0700007	Socket
1804	290426702	Heat-Sink x 4
1806	51102605E	B.H.M. Screw x 4
1808	289212004	Insulator x 4
1824	51102604E	B.H.M. Screw x 2
1809	289226702	Heat Sink x 2
1810	289226703	Heat Sink x 8
1811	281811806	Spacer x 8
1814	289205601	Buffer x 4
1816	289205501	Collar x 8
1830	53110301E	Hexagon Nut x 24
1831	54050300R	T.L. Washer OR x 12
1832	51100316E	B.H.M. Screw x 12
1833	54040302N	Spring Washer x 12
1834	54020301E	Flat Washer P x 4
<b>POWER AMP. CIRCUIT BOARD-P700</b>		
P700	YD2892004	P.W. Board, Power Amp x 2 (Print Only)
	ZZ2904104	P.W. Board Assembly x 2



REF. DESIG.	PART NO.	DESCRIPTION
		<b>P700-RESISTORS</b> All resistors are $\pm 5\%$ and $\frac{1}{4}W$ , unless otherwise indicated.
R701	RT0547414	470K $\Omega$ x 2
R702	RT0547414	470K $\Omega$ x 2
R703	RT0510214	1K $\Omega$ x 2
R704	RT0510214	1K $\Omega$ x 2
R705	RT0547314	47K $\Omega$ x 2
R706	RT0547314	47K $\Omega$ x 2
R707	RT0510214	1K $\Omega$ x 2
R708	RT0510214	1K $\Omega$ x 2
R709	RT0524214	2.4K $\Omega$ x 2
R710	RT0524214	2.4K $\Omega$ x 2
R711	RT0527414	270K $\Omega$ x 2
R712	RT0527414	270K $\Omega$ x 2
R713	RT0512314	12K $\Omega$ x 2
R714	RT0512314	12K $\Omega$ x 2
R715	RT0533014	33 $\Omega$
R716	RT0533014	33 $\Omega$
R717	RT0520114	200 $\Omega$ x 2
R718	RT0520114	200 $\Omega$ x 2
R719	RT0515314	15K $\Omega$ x 2
R720	RT0515314	15K $\Omega$ x 2
R721	RA0502017	Trimming, 5K $\Omega$ (B) $\pm 30\%$ x 2
R722	RA0502017	Trimming, 5K $\Omega$ (B) $\pm 30\%$ x 2
R723	RT0515314	15K $\Omega$ x 2
R724	RT0515314	15K $\Omega$ x 2
R725	GF0527212	2.7K $\Omega$ $\pm 5\%$ , $\frac{1}{4}W$ x 2
R726	GF0527212	2.7K $\Omega$ $\pm 5\%$ , $\frac{1}{4}W$ x 2
R727	RT0547314	47K $\Omega$ x 2
R728	RT0547314	47K $\Omega$ x 2
R729	RT0547014	47 $\Omega$ x 2
R730	RT0547014	47 $\Omega$ x 2
R731	RT0582014	82 $\Omega$ x 2
R732	RT0582014	82 $\Omega$ x 2
R733	RT0556314	56K $\Omega$ x 2
R734	RT0556314	56K $\Omega$ x 2
R735	RT0510114	100 $\Omega$ x 2
R736	RT0510114	100 $\Omega$ x 2
R737	GF0547012	47 $\Omega$ $\pm 5\%$ , $\frac{1}{4}W$ x 2
R738	GF0547012	47 $\Omega$ $\pm 5\%$ , $\frac{1}{4}W$ x 2
R739	RA0102020	Trimming, 1K $\Omega$ (B) $\pm 20\%$ x 2
R740	RA0102020	Trimming, 1K $\Omega$ (B) $\pm 20\%$ x 2
R741	GF0510112	100 $\Omega$ $\pm 5\%$ , $\frac{1}{4}W$ x 2
R742	GF0510112	100 $\Omega$ $\pm 5\%$ , $\frac{1}{4}W$ x 2
R743	GF0582014	82 $\Omega$ x 2
R744	GF0582014	82 $\Omega$ x 2
R745	GF0510112	100 $\Omega$ $\pm 5\%$ , $\frac{1}{4}W$ x 2
R746	GF0510112	100 $\Omega$ $\pm 5\%$ , $\frac{1}{4}W$ x 2
R747	RT0510214	1K $\Omega$ x 2
R748	RT0510214	1K $\Omega$ x 2
R749	GF0513114	130 $\Omega$ x 2
R750	GF0513114	130 $\Omega$ x 2
R751	GF0518214	1.8K $\Omega$ x 2
R752	GF0518214	1.8K $\Omega$ x 2
R753	GF0518214	1.8K $\Omega$ x 2
R754	GF0518214	1.8K $\Omega$ x 2
R755	RT0530214	3K $\Omega$ x 2
R756	RT0530214	3K $\Omega$ x 2
R757	GF0510114	100 $\Omega$ x 2
R758	GF0510114	100 $\Omega$ x 2
R759	GF0510114	100 $\Omega$ x 2
R760	GF0510114	100 $\Omega$ x 2

REF. DESIG.	PART NO.	DESCRIPTION
R761	BW1000205	0.2 $\Omega$ +0.2 $\Omega$ $\pm 10\%$ , 5W x 2
R762	BW1000205	0.2 $\Omega$ +0.2 $\Omega$ $\pm 10\%$ , 5W x 2
R763	RT0510014	10 $\Omega$ x 2
R764	RT0510014	10 $\Omega$ x 2
R765	GJ0510002	10 $\Omega$ $\pm 5\%$ , 2W x 2
R766	GJ0510002	10 $\Omega$ $\pm 5\%$ , 2W x 2
R767	GJ0502201	2.2 $\Omega$ $\pm 5\%$ , 1W x 2
R768	GJ0502201	2.2 $\Omega$ $\pm 5\%$ , 1W x 2
R769	RT0556014	56 $\Omega$ x 2
R770	RT0556014	56 $\Omega$ x 2
R771	RT0510214	1K $\Omega$ x 2
R772	RT0510214	1K $\Omega$ x 2
R773	GF0520114	200 $\Omega$ x 2
R774	GF0520114	200 $\Omega$ x 2
C701	EV3350106	Electroly, 3.3 $\mu F$ $\pm 20\%$ , 10V x 2
C702	EV3350106	Electroly, 3.3 $\mu F$ $\pm 20\%$ , 10V x 2
C703	DD1620101	Ceramic, 200PF $\pm 10\%$ x 2
C704	DD1620101	Ceramic, 200PF $\pm 10\%$ x 2
C705	DK1610150	Ceramic, 100PF $\pm 10\%$ x 2
C706	DK1610150	Ceramic, 100PF $\pm 10\%$ x 2
C707	DD1620101	Ceramic, 200PF $\pm 10\%$ x 2
C708	DD1620101	Ceramic, 200PF $\pm 10\%$ x 2
C709	EA4740501	Electroly, 0.47 $\mu F$ , 50V x 2
C710	EA4740501	Electroly, 0.47 $\mu F$ , 50V x 2
C711	EE4760163	Electroly, 47 $\mu F$ , 16V x 2
C712	EE4760163	Electroly, 47 $\mu F$ , 16V x 2
C713	ED2270509	Electroly, 220 $\mu F$ , 50V x 2
C714	ED2270509	Electroly, 220 $\mu F$ , 50V x 2
C715	ED2270509	Electroly, 220 $\mu F$ , 50V x 2
C716	ED2270509	Electroly, 220 $\mu F$ , 50V x 2
C717	DD1510050	Ceramic, 10PF $\pm 0.25PF$ , 500V x 2
C718	DD1510050	Ceramic, 10PF $\pm 0.25PF$ , 500V x 2
C719	DF1722305	Film, 0.022 $\mu F$ $\pm 20\%$ x 2
C720	DF1722305	Film, 0.022 $\mu F$ $\pm 20\%$ x 2
C721	DK1610150	Ceramic, 100PF $\pm 10\%$ x 2
C722	DK1610150	Ceramic, 100PF $\pm 10\%$ x 2
C723	DK1610150	Ceramic, 100PF $\pm 10\%$ x 2
C724	DK1610150	Ceramic, 100PF $\pm 10\%$ x 2
C727	DF1720301	Film, 0.02 $\mu F$ $\pm 20\%$ x 2
C728	DF1720301	Film, 0.02 $\mu F$ $\pm 20\%$ x 2
C729	DF1720301	Film, 0.02 $\mu F$ $\pm 20\%$ x 2
C730	DF1720301	Film, 0.02 $\mu F$ $\pm 20\%$ x 2
C731	DF1710452	Film, 0.1 $\mu F$ $\pm 20\%$ , 200V x 2
C732	DF1710452	Film, 0.1 $\mu F$ $\pm 20\%$ , 200V x 2
C733	DF1710305	Film, 0.01 $\mu F$ $\pm 20\%$ x 2
C734	DF1710305	Film, 0.01 $\mu F$ $\pm 20\%$ x 2
C735	EV1060036	Electroly, 10 $\mu F$ $\pm 20\%$ , 3.15V x 2
C736	EV1060036	Electroly, 10 $\mu F$ $\pm 20\%$ , 3.15V x 2
		<b>P700-SEMICONDUCTORS</b>
H701	HT107221S	Transistor, 2SA722S x 2
H702	HT107221S	Transistor, 2SA722S x 2
H703	HT107221S	Transistor, 2SA722S x 2
H704	HT107221S	Transistor, 2SA722S x 2
H705	HT107223A	Transistor, 2SA722ST or U x 2
H706	HT107223A	Transistor, 2SA722ST or U x 2
H707	HT306271B	Transistor, 2SC627B x 2
H708	HT306271B	Transistor, 2SC627B x 2
H709	HT306271B	Transistor, 2SC627B x 2
H710	HT306271B	Transistor, 2SC627B x 2
H711	HT304581B	Transistor, 2SC458B x 2

REF. DESIG.	PART NO.	DESCRIPTION
H712	HT304581B	Transistor, 2SC458B x 2
H713	HT403821M	Transistor, 2SD382M, L or K
H714	HT205371M	Transistor, 2SB537M, L or K
H715	HT403821M	Transistor, 2SD382M, L or K
H716	HT205371M	Transistor, 2SB537M, L or K
H717	HT309452A	Transistor, 2SC945Q or R x 2
H718	HT309452A	Transistor, 2SC945Q or R x 2
H719	HT309452A	Transistor, 2SC945Q or R x 2
H720	HT309452A	Transistor, 2SC945Q or R x 2
H721	HT107332B	Transistor, 2SA733Q or R x 2
H722	HT107332B	Transistor, 2SA733Q or R x 2
H723	HD3002709	Diode, WZ-140 x 2
H724	HD3002709	Diode, WZ-140 x 2
H725	HD2000121	Diode, 1S2473C (Ye) x 2
H726	HD2000121	Diode, 1S2473C (Ye) x 2
H727	HV0000408	Varistor, STV-3H (Gr) x 2
H728	HV0000408	Varistor, STV-3H (Gr) x 2
H729	HD2000121	Diode, 1S2473C (Ye) x 2
H730	HD2000121	Diode, 1S2473C (Ye) x 2
H731	HD2000221	Diode, 1S2472 (Gr) x 2
H732	HD2000221	Diode, 1S2472 (Gr) x 2
H733	HD2000221	Diode, 1S2472 (Gr) x 2
H734	HD2000221	Diode, 1S2472 (Gr) x 2
H735	HV0000206	Varistor, VD1212 x 2
H736	HV0000206	Varistor, VD1212 x 2
H738	HT205272A	Transistor, 2SB527C or D x 2
H728	HT205272A	Transistor, 2SB527C or D x 2
H739	HV0000206	Varistor, VD1212 x 2
H740	HV0000206	Varistor, VD1212 x 2
L701	LC2262001	Choke Coil x 2
L702	LC2262001	Choke Coil x 2
1922	289216005	Bracket
1929	51100305S	B.H.M. Screw x 2
1930	51100305S	B.H.M. Screw x 2
<b>POWER SUPPLY CIRCUIT BOARD-P800</b>		
P800	YD2904003	P.W. Board, Power Supply (Print Only)
	ZZ2904003	P.W. Board Assembly
<b>P800-RESISTORS</b>		
R801	GF0522214	2.2K $\Omega$ $\pm$ 5%, ¼W
R802	GS1015105	150 $\Omega$ $\pm$ 10%, 5W
R803	GU0533212	3.3K $\Omega$ $\pm$ 5%, ½W
R804	GJ0515202	1.5K $\Omega$ $\pm$ 5%, 2W
R805	GJ0510002	10 $\Omega$ $\pm$ 5%, 2W
R806	RT0547214	4.7K $\Omega$ $\pm$ 5%, ¼W
R807	RT0547214	4.7K $\Omega$ $\pm$ 5%, ¼W
R808	GU0539212	3.9K $\Omega$ $\pm$ 5%, ½W
R809	RT0556214	5.6K $\Omega$ $\pm$ 5%, ¼W
R810	RA0502017	Variable, 5K $\Omega$ (B)
R811	RT0522314	22K $\Omega$ $\pm$ 5%, ¼W
R812	GF0510014	10 $\Omega$ $\pm$ 5%, ¼W
R813	RT0510314	10K $\Omega$ $\pm$ 5%, ¼W
R814	RT0539414	390K $\Omega$ $\pm$ 5%, ¼W
R815	RT0539314	39K $\Omega$ $\pm$ 5%, ¼W
R816	RT0533314	33K $\Omega$ $\pm$ 5%, ¼W
R817	RT0510314	10K $\Omega$ $\pm$ 5%, ¼W
R818	RT0522314	22K $\Omega$ $\pm$ 5%, ¼W
R819	GJ0515202	1.5K $\Omega$ $\pm$ 5%, 2W

REF. DESIG.	PART NO.	DESCRIPTION
<b>P800-CAPACITORS</b>		
C801	DK1810351	Ceramic, 0.01 $\mu$ F +100%, -0%, 500V
C802	DK1810351	Ceramic, 0.01 $\mu$ F +100%, -0%, 500V
C803	EA2262501	Electroly, 22 $\mu$ F
C804	EA1063501	Electroly, 10 $\mu$ F, 350V
C805	EA1063501	Electroly, 10 $\mu$ F, 350V
C806	EA2270631	Electroly, 220 $\mu$ F, 63V
C807	ED1080631	Electroly, 1000 $\mu$ F, 63V
C808	EA2270169	Electroly, 220 $\mu$ F, 16V
C809	EA2262501	Electroly, 22 $\mu$ F, 250V
C810	EA2270509	Electroly, 220 $\mu$ F, 50V
C811	EA4770169	Electroly, 470 $\mu$ F, 16V
C812	EA2270169	Electroly, 220 $\mu$ F, 16V
C813	EA4770631	Electroly, 470 $\mu$ F, 63V
C814	EA3370509	Electroly, 330 $\mu$ F, 50V
C815	DF1747305	Film, 0.047 $\mu$ F, 50V
C816	EA4750359	Electroly, 4.7 $\mu$ F, 35V
C817	DF1710305	Film, 0.01 $\mu$ F, 50V
C818	EA4760639	Electroly, 47 $\mu$ F, 63V
C819	EA2270109	Electroly, 220 $\mu$ F, 10V
C820	EA4760109	Electroly, 47 $\mu$ F, 10V
<b>P800-SEMICONDUCTORS</b>		
H801	HD2001308	Diode, SD-1F (1500V)
H802	HD2001208	Diode, SD-1R (600V)
H803	HD2001208	Diode, SD-1R (600V)
H804	HD2001103	Rectifier, DS131B
H805	HD2001203	Rectifier, DS132B
H806	HD2001103	Rectifier, DS131B
H807	HD3002709	Zener Diode, WZ-140
H808	HD3002709	Zener Diode, WZ-140
H809	HD3002709	Zener Diode, WZ-140
H810	HD3002309	Zener Diode, WZ-071
H811	HT403314A	Transistor, 2SD331C, D, E, F
H812	HT403314A	Transistor, 2SD331C, D, E, F
H813	HT313183A	Transistor, 2SC1318P, Q, R
H814	HT309452A	Transistor, 2SC945Q, R
H815	HT313183A	Transistor, 2SC1318P, Q, R
H816	HT313183A	Transistor, 2SC1318P, Q, R
H817	HT309452A	Transistor, 2SC945Q, R
<b>P800-MISCELLANEOUS</b>		
J801	YP1000109	Plug
J809	YP1000109	Plug
J810	YJ0800017	Socket
J811	YJ0800017	Socket
J813	YP0600024	Plug
F801	FS1003004	Fuse, 3/8A (3AG)
F801	FS1003005	Fuse, 3/8A (MGC), For CANADA
1920	290426704	Heat Sink
1923	289226706	Heat Sink
1931	51100305S	B.H.M. Screw x 2
1932	51100310E	B.H.M. Screw x 2
1933	54050300R	T.L. Washer OR x 2
1934	53110301E	Hexagon Nut x 2
1935	51100305S	B.H.M. Screw x 2
<b>SCOPE AMP. CIRCUIT BOARD-P900</b>		
P900	YD2904009	P.W. Board, Scope Deflection Amp. (SE)
	ZZ2904009	P.W. Board Assembly (Print Only)

REF. DESIG.	PART NO.	DESCRIPTION
		<b>P900-RESISTORS</b> All resistors are $\pm 5\%$ and $\frac{1}{4}W$ , unless otherwise indicated.
R901	RT0522414	220K $\Omega$
R902	RT0522414	220K $\Omega$
R903	RT0522414	220K $\Omega$
R904	RT0522414	220K $\Omega$
R905	RT0568214	6.8K $\Omega$
R906	RT0568214	6.8K $\Omega$
R907	RT0547214	4.7K $\Omega$
R908	RT0547214	4.7K $\Omega$
R909	RA0502020	Trimming, 5K $\Omega$ (B)
R910	RA0502020	Trimming, 5K $\Omega$ (B)
R911	RT0510314	10K $\Omega$
R912	RT0510314	10K $\Omega$
R913	RT0510314	10K $\Omega$
R914	RT0510314	10K $\Omega$
R915	GU0568312	68K $\Omega \pm 5\%$ , $\frac{1}{2}W$
R916	GU0568312	68K $\Omega \pm 5\%$ , $\frac{1}{2}W$
R917	RA0102021	Trimming, 1K $\Omega$ (B)
R918	RA0102021	Trimming, 1K $\Omega$ (B)
R919	GU0562312	Trimming, 6.2K $\Omega \pm 5\%$ , $\frac{1}{2}W$
R920	GU0562312	Trimming, 6.2K $\Omega \pm 5\%$ , $\frac{1}{2}W$
R921	RT0522414	Trimming, 220K $\Omega$
R922	RT0510514	Trimming, 1M $\Omega$
R923	RT0510514	Trimming, 1M $\Omega$
R924	GU0582312	Trimming, 82K $\Omega \pm 5\%$ , $\frac{1}{2}W$
R925	GT0539401	Trimming, 390K $\Omega \pm 5\%$ , 1W
R926	RT0515514	Trimming, 1.5M $\Omega$
R927	RT0515314	Trimming, 15K $\Omega$
R928	RT0547314	Trimming, 47K $\Omega$
		<b>P900-CAPACITORS</b>
C901	DK1810382	Ceramic, 0.01 $\mu F + 100\%$ , -20%, 1KV DC
C902	DK1810382	Ceramic, 0.01 $\mu F + 100\%$ , -20%, 1KV DC
C903	DF1747352	Film, 0.047 $\mu F$ , 200V
		<b>P900-SEMICONDUCTORS</b>
H901		
H904	HF200300C	Transistor, 2SK30Y
H905		
H908	HT315071M	Transistor, 2SC1507
H909		
H911	HD2000321	Diode, 1S2472 (BI)
		<b>P900-MISCELLANEOUS</b>
1621	290426703	Heat-Sink x 2
1622	54040302N	Spring Washer x 4
1623	50020305B	R.H. Screw x 4
J901	YP0600024	Plug, 11P
J902		
J925	YP1000113	Plug
J041	YJ0500018	Socket, C.R.T.
		<b>BUFFER PRE-AMP CIRCUIT BOARD-PE01</b>
PE01	YD2892005	P.W. Board, Buffer Pre-Amp.(Print Only)
	ZZ2892005	P.W. Board Assembly

REF. DESIG.	PART NO.	DESCRIPTION
		<b>PE01-RESISTORS</b> All resistors are $\pm 5\%$ and $\frac{1}{4}W$ .
RE01	RT0515414	150K $\Omega$
RE02	RT0515414	150K $\Omega$
RE03	RT0515414	150K $\Omega$
RE04	RT0515414	150K $\Omega$
RE05	RT0510214	1K $\Omega$
RE06	RT0510214	1K $\Omega$
RE07	RT0510214	1K $\Omega$
RE08	RT0510214	1K $\Omega$
RE09	RN0510514	1M $\Omega$
RE10	RN0510514	1M $\Omega$
RE11	RN0510514	1M $\Omega$
RE12	RN0510514	1M $\Omega$
RE13	RN0591414	910K $\Omega$
RE14	RN0591414	910K $\Omega$
RE15	RN0591414	910K $\Omega$
RE16	RN0591414	910K $\Omega$
RE17	RT0536314	36K $\Omega$
RE18	RT0536314	36K $\Omega$
RE19	RT0536314	36K $\Omega$
RE20	RT0536314	36K $\Omega$
RE25	RT0522314	22K $\Omega$
RE26	RT0522314	22K $\Omega$
RE27	RT0522314	22K $\Omega$
RE28	RT0522314	22K $\Omega$
RE29	RT0575014	75 $\Omega$
RE30	RT0575014	75 $\Omega$
RE31	RT0575014	75 $\Omega$
RE32	RT0575014	75 $\Omega$
RE33	RT0522114	220 $\Omega$
RE34	RT0522114	220 $\Omega$
RE35	RT0522114	220 $\Omega$
RE36	RT0522114	220 $\Omega$
RE37	RT0510414	100K $\Omega$
RE38	RT0510414	100K $\Omega$
RE39	RT0510414	100K $\Omega$
RE40	RT0510414	100K $\Omega$
RE41	RT0547414	470K $\Omega$
RE42	RT0547414	470K $\Omega$
RE43	RT0547414	470K $\Omega$
RE44	RT0547414	470K $\Omega$
RE45	RT0510214	1K $\Omega$
RE46	RT0510214	1K $\Omega$
RE47	RT0510214	1K $\Omega$
RE48	RT0510214	1K $\Omega$
RE49	RT0547314	47K $\Omega$
RE50	RT0547314	47K $\Omega$
RE51	RT0547314	47K $\Omega$
RE52	RT0547314	47K $\Omega$
RE53	RT0510314	10K $\Omega$
RE54	RT0510314	10K $\Omega$
RE55	RT0510314	10K $\Omega$
RE56	RT0510314	10K $\Omega$
RE57	RT0510414	100K $\Omega$
RE58	RT0510414	100K $\Omega$
RE59	RT0510414	100K $\Omega$
RE60	RT0510414	100K $\Omega$
RE61	RT0527314	27K $\Omega$
RE62	RT0527314	27K $\Omega$
RE63	RT0527314	27K $\Omega$
RE64	RT0527314	27K $\Omega$

REF. DESIG.	PART NO.	DESCRIPTION
RE65	RT0510214	1K $\Omega$
RE66	RT0510214	1K $\Omega$
RE67	RT0510214	1K $\Omega$
RE68	RT0510214	1K $\Omega$
RE69	RT0556214	5.6K $\Omega$
RE70	RT0556214	5.6K $\Omega$
RE71	RT0556214	5.6K $\Omega$
RE72	RT0556214	5.6K $\Omega$
RE73	RT0510214	1K $\Omega$
RE74	RT0510214	1K $\Omega$
RE75	RT0510214	1K $\Omega$
RE76	RT0510214	1K $\Omega$
RE77	RT0522414	220K $\Omega$
RE78	RT0522414	220K $\Omega$
RE79	RT0522414	220K $\Omega$
RE80	RT0522414	220K $\Omega$
RE81	RT0547114	470 $\Omega$
<b>PE01-CAPACITORS</b>		
CE01	DF1722405	Film, 0.22 $\mu$ F $\pm$ 20%
CE02	DF1722405	Film, 0.22 $\mu$ F $\pm$ 20%
CE03	DF1722405	Film, 0.22 $\mu$ F $\pm$ 20%
CE04	DF1722405	Film, 0.22 $\mu$ F $\pm$ 20%
CE05	EE2260251	Electroly, 22 $\mu$ F $\pm$ 20%, 25V
CE06	EE2260251	Electroly, 22 $\mu$ F $\pm$ 20%, 25V
CE07	EE2260251	Electroly, 22 $\mu$ F $\pm$ 20%, 25V
CE08	EE2260251	Electroly, 22 $\mu$ F $\pm$ 20%, 25V
CE09	EV2250256	Electroly, 2.2 $\mu$ F $\pm$ 20%, 25V
CE10	EV2250256	Electroly, 2.2 $\mu$ F $\pm$ 20%, 25V
CE11	EV2250256	Electroly, 2.2 $\mu$ F $\pm$ 20%, 25V
CE12	EV2250256	Electroly, 2.2 $\mu$ F $\pm$ 20%, 25V
CE13	EV4750356	Electroly, 4.7 $\mu$ F $\pm$ 20%, 35V
CE14	EV4750356	Electroly, 4.7 $\mu$ F $\pm$ 20%, 35V
CE15	EV4750356	Electroly, 4.7 $\mu$ F $\pm$ 20%, 35V
CE16	EV4750356	Electroly, 4.7 $\mu$ F $\pm$ 20%, 35V
CE17	EA4760359	Electroly, 47 $\mu$ F, 35V
CE18	EA4760359	Electroly, 47 $\mu$ F, 35V
CE19	EA4760359	Electroly, 47 $\mu$ F, 35V
CE20	EA4760359	Electroly, 47 $\mu$ F, 35V
CE21	EA2270359	Electroly, 220 $\mu$ F, 35V
CE22	EA2270359	Electroly, 220 $\mu$ F, 35V
CE23	DF1747305	Film, 0.047 $\mu$ F $\pm$ 20%, 50V
<b>PE01-SEMICONDUCTORS</b>		
HE01	HT313452A	Transistor, 2SC1345D or E
HE02	HT313452A	Transistor, 2SC1345D or E
HE03	HT313452A	Transistor, 2SC1345D or E
HE04	HT313452A	Transistor, 2SC1345D or E
HE05	HT107202A	Transistor, 2SA720R or S
HE06	HT107202A	Transistor, 2SA720R or S
HE07	HT107202A	Transistor, 2SA720R or S
HE08	HT107202A	Transistor, 2SA720R or S
HE09	HT313182Q	Transistor, 2SC1318Q or R
HE10	HT313182Q	Transistor, 2SC1318Q or R
HE11	HT313182Q	Transistor, 2SC1318Q or R
HE12	HT313182Q	Transistor, 2SC1318Q or R
HE13	HT313452A	Transistor, 2SC1345D or E
HE14	HT313452A	Transistor, 2SC1345D or E
HE15	HT313452A	Transistor, 2SC1345D or E
HE16	HT313452A	Transistor, 2SC1345D or E
HE17	HT107632A	Transistor, 2SA763W
HE18	HT107632A	Transistor, 2SA763W
HE19	HT107632A	Transistor, 2SA763W
HE20	HT107632A	Transistor, 2SA763W

REF. DESIG.	PART NO.	DESCRIPTION
HE21	HV0000206	Varistor, VD1212
HE22	HV0000206	Varistor, VD1212
HE23	HV0000206	Varistor, VD1212
HE24	HV0000206	Varistor, VD1212
<b>PE01-MISCELLANEOUS</b>		
JE01	YP1000113	Plug
JE33		
1007	288310401	Retainer
1008	51102605A	B.H.M. Screw
<b>TONE CONTROL CIRCUIT BOARD-PF01</b>		
PF01	YD2904010 ZZ2904010	P.W. Board, Tone Assy, Diode Matrix P.W. Board Assembly (Print Only)
<b>PF01-RESISTORS</b>		
All resistors are $\pm$ 5% and $\frac{1}{4}$ W, unless otherwise indicated.		
RF01	RU0104001	Variable, 100K $\Omega$ (B)
RF02	RU0204001	Variable, 200K $\Omega$ (B)
RF03	RU0204001	Variable, 200K $\Omega$ (B)
RF04	RT0515314	15K $\Omega$
RF05	RT0515314	15K $\Omega$
RF06	RT0515314	15K $\Omega$
RF07	RT0515314	15K $\Omega$
RF08	RT0515314	15K $\Omega$
RF09	RT0515314	15K $\Omega$
RF10	RT0515314	15K $\Omega$
RF11	RT0515314	15K $\Omega$
RF12	RT0527314	27K $\Omega$
RF13	RT0527314	27K $\Omega$
RF14	RT0527314	27K $\Omega$
RF15	RT0527314	27K $\Omega$
RF16	RT0520314	20K $\Omega$
RF17	RT0520314	20K $\Omega$
RF18	RT0520314	20K $\Omega$
RF19	RT0520314	20K $\Omega$
RF20	RT0510314	10K $\Omega$
RF21	RT0510314	10K $\Omega$
RF22	RT0510314	10K $\Omega$
RF23	RT0510314	10K $\Omega$
RF24	RT0510314	10K $\Omega$
RF25	RT0510314	10K $\Omega$
RF26	RT0510314	10K $\Omega$
RF27	RT0510314	10K $\Omega$
RF28	RT0510314	10K $\Omega$
RF29	RT0510314	10K $\Omega$
RF30	RT0510314	10K $\Omega$
RF31	RT0510314	10K $\Omega$
RF32	RT0510314	10K $\Omega$
RF33	RT0510314	10K $\Omega$
RF34	RT0510314	10K $\Omega$
RF35	RT0510314	10K $\Omega$
RF36	RT0543414	430K $\Omega$
RF37	RT0543414	430K $\Omega$
RF38	RT0543414	430K $\Omega$
RF39	RT0543414	430K $\Omega$
RF40	RT0568414	680K $\Omega$
RF41	RT0568414	680K $\Omega$
RF42	RT0568414	680K $\Omega$
RF43	RT0568414	680K $\Omega$

REF. DESIG.	PART NO.	DESCRIPTION	REF. DESIG.	PART NO.	DESCRIPTION
RF44	RT0510414	100K $\Omega$	CF26	DF1710305	Film, 0.01 $\mu$ F $\pm$ 20%, 50V
RF45	RT0510414	100K $\Omega$	CF27	DF1710305	Film, 0.01 $\mu$ F $\pm$ 20%, 50V
RF46	RT0510414	100K $\Omega$	CF28	DF1710305	Film, 0.01 $\mu$ F $\pm$ 20%, 50V
RF47	RT0510414	100K $\Omega$	CF31	EA1060169	Electroly, 10 $\mu$ F, 16V
RF48	RT0510414	100K $\Omega$	CF32	EA1060169	Electroly, 10 $\mu$ F, 16V
RF49	RT0510414	100K $\Omega$			
RF50	RT0510514	1M $\Omega$	CF33	EA1060169	Electroly, 10 $\mu$ F, 16V
			CF34	EA1060169	Electroly, 10 $\mu$ F, 16V
RF51	RT0510514	1M $\Omega$			<b>PF01-SEMICONDUCTORS</b>
RF52	RT0510514	1M $\Omega$	HF01	HF200301C	Transistor, 2SK30A (Y)
RF53	RT0510514	1M $\Omega$	HF02	HF200301C	Transistor, 2SK30A (Y)
RF54	RT0533114	330 $\Omega$	HF03	HF200301C	Transistor, 2SK30A (Y)
RF55	RT0533114	330 $\Omega$	HF04	HF200301C	Transistor, 2SK30A (Y)
RF56	RT0533114	330 $\Omega$	HF05	HD1000302	Diode, 20A90M
RF57	RT0533114	330 $\Omega$	HF06	HD1000302	Diode, 20A90M
RF58	RT0556214	5.6K $\Omega$	HF07	HD1000302	Diode, 20A90M
RF59	RT0556214	5.6K $\Omega$	HF08	HD1000302	Diode, 20A90M
RF60	RT0556214	5.6K $\Omega$			
RF61	RT0556214	5.6K $\Omega$			<b>TONE AMP. CIRCUIT BOARD-PD01</b>
RF62	RT0556214	5.6K $\Omega$	PD01	YD2889002	P.W. Board, Tone Amp. (Print Only)
RF63	RT0556214	5.6K $\Omega$		ZZ2904102	P.W. Board Assembly
RF64	RT0556214	5.6K $\Omega$			<b>PD01-RESISTORS</b>
RF65	RT0556214	5.6K $\Omega$			All resistors are $\pm$ 5% and $\frac{1}{4}$ W, unless otherwise indicated.
RF66	RT0556214	5.6K $\Omega$	RD01	RN1022514	2.2M $\Omega$ $\pm$ 10%, $\frac{1}{4}$ W
RF67	RT0556214	5.6K $\Omega$	RD02	RN1022514	2.2M $\Omega$ $\pm$ 10%, $\frac{1}{4}$ W
RF68	RT0556214	5.6K $\Omega$	RD03	RN1022514	2.2M $\Omega$ $\pm$ 10%, $\frac{1}{4}$ W
RF69	RT0556214	5.6K $\Omega$	RD04	RN1022514	2.2M $\Omega$ $\pm$ 10%, $\frac{1}{4}$ W
RF70	RT0556214	5.6K $\Omega$	RD05	RT0575314	75K $\Omega$
			RD06	RT0575314	75K $\Omega$
RF71	RT0556214	5.6K $\Omega$	RD07	RT0575314	75K $\Omega$
RF72	RT0556214	5.6K $\Omega$	RD08	RT0575314	75K $\Omega$
RF73	RT0556214	5.6K $\Omega$	RD09	RT0547314	47K $\Omega$
RF74	RT0556214	5.6K $\Omega$	RD10	RT0547314	47K $\Omega$
RF75	RT0556214	5.6K $\Omega$			
RF76	RT0556214	5.6K $\Omega$	RD11	RT0547314	47K $\Omega$
RF77	RT0556214	5.6K $\Omega$	RD12	RT0547314	47K $\Omega$
RF78	RT0510414	100K $\Omega$	RD13	RT0510314	10K $\Omega$
RF79	RT0510414	100K $\Omega$	RD14	RT0510314	10K $\Omega$
			RD15	RT0510314	10K $\Omega$
			RD16	RT0510314	10K $\Omega$
			RD17	RT0522114	220 $\Omega$
			RD18	RT0522114	220 $\Omega$
			RD19	RT0522114	220 $\Omega$
			RD20	RT0522114	220 $\Omega$
			RD21	RT0510414	100K $\Omega$
			RD22	RT0510414	100K $\Omega$
			RD23	RT0510414	100K $\Omega$
			RD24	RT0510414	100K $\Omega$
					<b>PD01-CAPACITORS</b>
CF01	DF1622305	Film, 0.022 $\mu$ F $\pm$ 10%, 50V	CD01	EV1050256	Electroly, 1 $\mu$ F $\pm$ 20%, 25V
CF02	DF1622305	Film, 0.022 $\mu$ F $\pm$ 10%, 50V	CD02	EV1050256	Electroly, 1 $\mu$ F $\pm$ 20%, 25V
CF03	DF1622305	Film, 0.022 $\mu$ F $\pm$ 10%, 50V	CD03	EV1050256	Electroly, 1 $\mu$ F $\pm$ 20%, 25V
CF04	DF1622305	Film, 0.022 $\mu$ F $\pm$ 10%, 50V	CD04	EV1050256	Electroly, 1 $\mu$ F $\pm$ 20%, 25V
CF05	DF1622305	Film, 0.022 $\mu$ F $\pm$ 10%, 50V	CD05	EV3350356	Electroly, 3.3 $\mu$ F $\pm$ 20%, 35V
CF06	DF1622305	Film, 0.022 $\mu$ F $\pm$ 10%, 50V	CD06	EV3350356	Electroly, 3.3 $\mu$ F $\pm$ 20%, 35V
CF07	DF1622305	Film, 0.022 $\mu$ F $\pm$ 10%, 50V	CD07	EV3350356	Electroly, 3.3 $\mu$ F $\pm$ 20%, 35V
CF08	DF1622305	Film, 0.022 $\mu$ F $\pm$ 10%, 50V	CD08	EV3350356	Electroly, 3.3 $\mu$ F $\pm$ 20%, 35V
CF09	DF1668205	Film, 6800PF $\pm$ 10%, 50V	CD09	EQ4750161	Electroly, 4.7 $\mu$ F $\pm$ 30%, 16V
CF10	DF1668205	Film, 6800PF $\pm$ 10%, 50V	CD10	EQ4750161	Electroly, 4.7 $\mu$ F $\pm$ 30%, 16V
CF11	DF1668205	Film, 6800PF $\pm$ 10%, 50V			
CF12	DF1668205	Film, 6800PF $\pm$ 10%, 50V	CD11	EQ4750161	Electroly, 4.7 $\mu$ F $\pm$ 30%, 16V
CF13	DF1615205	Film, 1500PF $\pm$ 10%, 50V	CD12	EQ4750161	Electroly, 4.7 $\mu$ F $\pm$ 30%, 16V
CF14	DF1615205	Film, 1500PF $\pm$ 10%, 50V			
CF15	DF1615205	Film, 1500PF $\pm$ 10%, 50V			
CF16	DF1615205	Film, 1500PF $\pm$ 10%, 50V			
CF17	DF1633205	Film, 3300PF $\pm$ 10%, 50V			
CF18	DF1633205	Film, 3300PF $\pm$ 10%, 50V			
CF19	DF1633205	Film, 3300PF $\pm$ 10%, 50V			
CF20	DF1633205	Film, 3300PF $\pm$ 10%, 50V			
CF21	DD1650001	Ceramic, 50PF $\pm$ 10%, 50V			
CF22	DD1650001	Ceramic, 50PF $\pm$ 10%, 50V			
CF23	DD1650001	Ceramic, 50PF $\pm$ 10%, 50V			
CF24	DD1650001	Ceramic, 50PF $\pm$ 10%, 50V			
CF25	DF1710305	Film, 0.01 $\mu$ F $\pm$ 20%, 50V			

REF. DESIG.	PART NO.	DESCRIPTION	REF. DESIG.	PART NO.	DESCRIPTION
		<b>PD01-SEMICONDUCTORS</b>	HL08	HD1000105	Diode, 1N60
HD01	HT313452A	Transistor, 2SC1345D or E	HL09	HD1000105	Diode, 1N60
HD02	HT313452A	Transistor, 2SC1345D or E	HL10	HD1000105	Diode, 1N60
HD03	HT313452A	Transistor, 2SC1345D or E	HL11	HD1000105	Diode, 1N60
HD04	HT313452A	Transistor, 2SC1345D or E			
HD05	HT107632A	Transistor, 2SA763 (4), (5)			
HD06	HT107632A	Transistor, 2SA763 (4), (5)	JL01		
HD07	HT107632A	Transistor, 2SA763 (4), (5)	}	YP1000113	Plug
HD08	HT107632A	Transistor, 2SA763 (4), (5)	JL09		
		<b>DOLBY TONE METER CIRCUIT BOARD-PL01</b>			
PL01	YD2886009 ZZ2886009	P.W. Board, Dolby Tone & Meter P.W. Board Assembly (Print Only)	PM01	YD2890008 ZZ2904208	<b>B.T.L. CIRCUIT BOARD-PM01</b> P.W. Board, B.T.L. (Print Only) P.W. Board Assembly
		<b>PL01-RESISTORS</b> All resistors are $\pm 5\%$ and $\frac{1}{4}W$ , unless otherwise indicated.			<b>PM01-RESISTORS</b> All resistors are $\pm 5\%$ and $\frac{1}{4}W$ .
RL01	RT0533214	3.3K $\Omega$	RM01	RT0533114	330 $\Omega$
RL02	RT0547314	47K $\Omega$	RM02	RT0533114	330 $\Omega$
RL03	RT0510114	100 $\Omega$	RM03	RN0533414	330K $\Omega$
RL04	RT0533214	3.3K $\Omega$	RM04	RN0533414	330K $\Omega$
RL05	RT0510214	1K $\Omega$	RM05	RN0515414	150K $\Omega$
RL06	RT0512314	12K $\Omega$	RM06	RN0515414	150K $\Omega$
RL07	RT0547314	47K $\Omega$	RM07	RT0582314	82K $\Omega$
RL08	RT0510214	1K $\Omega$	RM08	RT0582314	82K $\Omega$
RL09	RT0547214	4.7K $\Omega$	RM09	RT0575214	7.5K $\Omega$
RL10	RT0510214	1K $\Omega$	RM10	RT0575214	7.5K $\Omega$
RL11	RA0501012	Trimming, 500 $\Omega$ (B)	RM11	RT0556214	5.6K $\Omega$
RL12	RA0502019	Trimming, 5K $\Omega$ (B)	RM12	RT0556214	5.6K $\Omega$
RL13	RT0556314	56K $\Omega$	RM13	RT0547414	470K $\Omega$
RL14	RT0556314	56K $\Omega$	RM14	RT0547414	470K $\Omega$
RL15	RT0547214	4.7K $\Omega$	RM15	RT0533114	330 $\Omega$
RL16	RT0533314	33K $\Omega$	RM16	RT0547414	470K $\Omega$
RL20	RT0568414	680K $\Omega$	RM17	RT0547414	470K $\Omega$
RL21	RT0568414	680K $\Omega$			
RL22	RT0533414	330K $\Omega$	CM01	EE3350501	Electroly, 3.3 $\mu F$ , 50V
RL23	RT0533414	330K $\Omega$	CM02	EE3350501	Electroly, 3.3 $\mu F$ , 50V
RL24	RT0533214	3.3K $\Omega$	CM03	EE3350501	Electroly, 3.3 $\mu F$ , 50V
RL25	RT0533214	3.3K $\Omega$	CM04	EE3350501	Electroly, 3.3 $\mu F$ , 50V
RL26	RT0515214	1.5K $\Omega$	CM05	EA1070359	Electroly, 100 $\mu F$ , 35V
RL27	RT0515214	1.5K $\Omega$			
RL28	RA0152004	Trimming, 1.5K $\Omega$ (B)			
RL29	RA0152004	Trimming, 1.5K $\Omega$ (B)	HM01	HT313452A	Transistor, 2SC1345D, E
		<b>PL01-CAPACITORS</b>	HM02	HT107632A	Transistor, 2SA763 (4), (5)
CL01	DF1515305	Film, 0.015 $\mu F \pm 5\%$	HM03	HT313452A	Transistor, 2SC1345D, E
CL02	DF1515305	Film, 0.015 $\mu F \pm 5\%$	HM04	HT107632A	Transistor, 2SA763 (4), (5)
CL03	DF1668301	Film, 0.068 $\mu F \pm 10\%$			
CL04	DF1710402	Film, 0.1 $\mu F \pm 20\%$	JM01		
CL05	EA1060169	Electroly, 10 $\mu F$ , 16V	}	YP1000113	Plug
CL06	EA1060169	Electroly, 10 $\mu F$ , 16V	JM13		
CL07	EA1060169	Electroly, 10 $\mu F$ , 16V			
CL10	EA1060169	Electroly, 10 $\mu F$ , 16V	1509	62031650W	Lug
CL11	EA1060169	Electroly, 10 $\mu F$ , 16V			
CL12	EA4750359	Electroly, 4.7 $\mu F$ , 35V			
CL13	EA4750359	Electroly, 4.7 $\mu F$ , 35V	PH01	YD2904004 ZZ2904004	<b>FILTER AMP. CIRCUIT BOARD-PH01</b> P.W. Board, Filter Amp. (Print Only) P.W. Board Assembly
CL14	EA3360359	Electroly, 33 $\mu F$ , 35V			
		<b>PL01-SEMICONDUCTORS</b>			<b>PH01-RESISTORS</b> All resistors are $\pm 5\%$ and $\frac{1}{4}W$ .
HL01	HT307331C	Transistor, 2SC733 (Gr)	RH01	RT0568214	6.8K $\Omega$
HL02	HT307331C	Transistor, 2SC733 (Gr)	RH02	RT0556214	5.6K $\Omega$
HL03	HT307331C	Transistor, 2SC733 (Gr)	RH03	RT0515214	1.5K $\Omega$
HL06	HT307331C	Transistor, 2SC733 (Gr)	RH04	RN0518514	1.8M $\Omega$
HL07	HT307331C	Transistor, 2SC733 (Gr)	RH05	RN0518514	1.8M $\Omega$

REF. DESIG.	PART NO.	DESCRIPTION
RH06	RN0518514	1.8M $\Omega$
RH07	RN0518514	1.8M $\Omega$
RH08	RT0522314	22K $\Omega$
RH09	RT0522314	22K $\Omega$
RH10	RT0522314	22K $\Omega$
RH11	RT0522314	22K $\Omega$
RH12	RT0547214	4.7K $\Omega$
RH13	RT0547214	4.7K $\Omega$
RH14	RT0547214	4.7K $\Omega$
RH15	RT0547214	4.7K $\Omega$
RH16	RT0522414	220K $\Omega$
RH17	RT0522414	220K $\Omega$
RH18	RT0522414	220K $\Omega$
RH19	RT0522414	220K $\Omega$
RH20	RT0522114	220 $\Omega$
RH21	RT0522114	220 $\Omega$
RH22	RT0522114	220 $\Omega$
RH23	RT0522114	220 $\Omega$
RH24	RT0518514	1.8M $\Omega$
RH25	RT0518514	1.8M $\Omega$
RH26	RT0518514	1.8M $\Omega$
RH27	RT0518514	1.8M $\Omega$
CH01	DF1722405	Film, 0.22 $\mu$ F $\pm$ 20%, 50V
CH02	DF1722405	Film, 0.22 $\mu$ F $\pm$ 20%, 50V
CH03	DF1722405	Film, 0.22 $\mu$ F $\pm$ 20%, 50V
CH04	DF1722405	Film, 0.22 $\mu$ F $\pm$ 20%, 50V
CH05	EV4750256	Electroly, 4.7 $\mu$ F $\pm$ 20%, 25V
CH06	EV4750256	Electroly, 4.7 $\mu$ F $\pm$ 20%, 25V
CH07	EV4750256	Electroly, 4.7 $\mu$ F $\pm$ 20%, 25V
CH08	EV4750256	Electroly, 4.7 $\mu$ F $\pm$ 20%, 25V
CH09	EA3370259	Electroly, 330 $\mu$ F, 25V
CH10	DK1750201	Ceramic, 0.005 $\mu$ F, 50V
CH11	DK1750201	Ceramic, 0.005 $\mu$ F, 50V
CH12	DK1750201	Ceramic, 0.005 $\mu$ F, 50V
CH13	DK1750201	Ceramic, 0.005 $\mu$ F, 50V
HH01	HT313442A	Transistor, 2SC1344D, E
HH02	HT313442A	Transistor, 2SC1344D, E
HH03	HT313442A	Transistor, 2SC1344D, E
HH04	HT313442A	Transistor, 2SC1344D, E
HH05	HT107632A	Transistor, 2SA763 4 or 5
HH06	HT107632A	Transistor, 2SA763 4 or 5
HH07	HT107632A	Transistor, 2SA763 4 or 5
HH08	HT107632A	Transistor, 2SA763 4 or 5
JH01	YP1000113	Plug
JH17	YP1000113	Plug
0903	290416050	Bracket K
0909	289212201	Sticker
0913	257710602	Bearing
0914	141511801	Spacer
0915	51040306A	F.H.M. Screw x 2
0919	51102612S	B.H.M. Screw x 2
0920	51100304S	B.H.M. Screw
0933	51102604A	B.H.M. Screw x 2
1011	51100305A	B.H.M. Screw x 6
1013	51060305A	P.H.M. Screw x 6
1016	261105501	Collar x 2

REF. DESIG.	PART NO.	DESCRIPTION
1025	290410102	Support x 2
1026	288810102	Support x 2
1027	290427401	Reflector
1028	290405301	Cover
1029	51100305S	B.H.M. Screw x 2
1030	51100304S	B.H.M. Screw x 2
1133	51042608A	F.H.M. Screw x 2
1616	51470306A	B.H.M. Screw x 2
8851	288612002	Insulator
R015	RK0504010	Variable Resist., 500K $\Omega$ (B) Play Cal-Dolby
R016	RK0504010	Variable Resist., 500K $\Omega$ (B) Play Cal-Dolby
R017	RK0504010	Variable Resist., 500K $\Omega$ (B) Rec Level-Dolby
R018	RK0504010	Variable Resist., 500K $\Omega$ (B) Rec Level-Dolby
S007	SP0202010	Push Switch, Power Supply
G001	BF1040001	Printed Comp., 0.1 $\mu$ F + 120 $\Omega$
1032	290416006	Bracket
1033	51100305A	B.H.M. Screw x 2
R019	RG0503002	Variable Resist., 50K $\Omega$ (B) Volume
PT01	YD2904006	<b>PUSH-SWITCH ASS'Y BOARD-PT01</b> P.W. Board, Push Switch Ass'y (Print only)
	ZZ2904006	P.W. Board Assembly
RT01	RT0547314	<b>PT01-RESISTORS</b> 47K $\Omega$ $\pm$ 5%, $\frac{1}{4}$ W
RT02	RT0556014	56 $\Omega$ $\pm$ 5%, $\frac{1}{4}$ W
RT03	RT0510114	100 $\Omega$ $\pm$ 5%, $\frac{1}{4}$ W
RT04	RT0515214	1.5K $\Omega$ $\pm$ 5%, $\frac{1}{4}$ W
RT05	RT0522414	220K $\Omega$ $\pm$ 5%, $\frac{1}{4}$ W
RT06	RT0527414	270K $\Omega$ $\pm$ 5%, $\frac{1}{4}$ W
RT07	RT0527414	270K $\Omega$ $\pm$ 5%, $\frac{1}{4}$ W
RT08	RT0510314	10K $\Omega$ $\pm$ 5%, $\frac{1}{4}$ W
RT09	RA0103025	10K $\Omega$ (B) Centering
RT10	RA0503012	50K $\Omega$ (B) Multipath
CT01	DF1647305	<b>PT01-CAPACITORS</b> Film, 0.047 $\mu$ F $\pm$ 10%, 50V
CT02	DF1722405	Film, 0.22 $\mu$ F $\pm$ 20%, 50V
CT03	DF1733405	Film, 0.33 $\mu$ F $\pm$ 20%, 50V
ST01	SP0806002	<b>PT01-MISCELLANEOUS</b> Push Switch, 400Hz Tone & Scope Mode
JT01	YP1000120	Plug
JT07	YP1000120	Plug
J034	YJ0600020	<b>GENERAL MISCELLANEOUS</b> Jack
1606	285310650	Bearing K
1611	51640412D	Set Screw C.P.
1612	54040402N	Spring Washer
1613	53110403E	Hexagon Nut
0931	285310901	Shield
0932	282112001	Insulator
PG01	YD2904002	<b>BALANCE CONTROL CIRCUIT BOARD-PG01</b> P.W. Board, Balance Control (Print Only)
	ZZ2904002	P.W. Board Assembly
RG01	RS0503020	<b>PG01-MISCELLANEOUS</b> Variable Resist., 50K $\Omega$ BH (2G)

REF. DESIG.	PART NO.	DESCRIPTION
RG02	RS0503020	Variable Resist., 50KΩ BH (2G)
RG03	NA0503001	Variable Resist., 50KΩ BH (4G)
JG01 }	YP1000113	Plug
JG09		
		<b>GENERAL MISCELLANEOUS</b>
1103	289227401	Reflector
1105	289227101	Holder
1106	51570305B	P.H. Tapt Screw x 2
1108	289227102	Holder
1109	51570305B	P.H. Tapt Screw x 2
1111	51100305A	B.H.M. Screw x 2
1113	51480306A	B.H.M. Screw F x 2
R008	RC1022012	Resistor, 22Ω ± 10%, ¼W
R009	RC1022012	Resistor, 22Ω ± 10%, ¼W
R010	RC1010012	Resistor, 10Ω ± 10%, ¼W
		<b>FUNCTION INDICATORS BOARD-PY01</b>
PY01	YD2904001 ZZ2904001	P.W. Board, Function Indicator (Print Only) P.W. Board Assembly
		<b>PY01-MISCELLANEOUS</b>
MY01	IN1006301	Lamp, 6.3V, 40mA, Dolby
MY02	IN1006301	Lamp, 6.3V, 40mA (FM)
MY03	IN1006301	Lamp, 6.3V, 40mA (AM)
MY04	IN1012011	Lamp, 12V, 40mA, Stereo
MY05	IN1006301	Lamp, 6.3V, 180mA (4CH)
MY06	IN1006301	Lamp, 6.3V, 40mA (AUX)
MY07	IN1006301	Lamp, 6.3V, 40mA (PHONO)
MY08	IN1006301	Lamp, 6.3V, 40mA (TAPE-2)
MY09	IN1006301	Lamp, 6.3V, 40mA (TAPE-1)
JY01 }	YP1000113	Plug
JY13		
		<b>DIAL LAMPS BOARD-PZ01</b>
PZ01	YD2892001 ZZ2904101	P.W. Board, SE Material, Dial Lamp P.W. Board Assembly
		<b>PZ01-MISCELLANEOUS</b>
MZ01 }	IN1008036	Lamp, 8V, Dial Lamp
MZ06		
JZ01 }	YJ0800017	Socket
JZ12		
JZ13 }	YP1000113	Plug
JZ18		
		<b>GENERAL MISCELLANEOUS</b>
1116	289205101	Guide
1118	289226252	Pulley K
1125	289226253	Pulley K
1132	51570305B	P.H. Tapt Screw x 4
		<b>HEADPHONE ASS'Y BOARD-PW01</b>
PW01	YD2892013 ZZ2904113	P.W. Board, Headphone (Print Only) P.W. Board Assembly

REF. DESIG.	PART NO.	DESCRIPTION
		<b>PW01-MISCELLANEOUS</b>
RW01	GF0515112	Resistor, 150Ω ± 5%, ¼W
RW02	GF0515112	Resistor, 150Ω ± 5%, ¼W
RW03	GF0515112	Resistor, 150Ω ± 5%, ¼W
RW04	GF0515112	Resistor, 150Ω ± 5%, ¼W
JW01	YP1000120	Plug
JW02	YP1000120	Plug
JW03	YP1000120	Plug
JW04	YP1000120	Plug
JW05	YP1000120	Plug
JW06	YP1000120	Plug
JW07	YP1000120	Plug
JW08	YJ0100086	Jack, Headphone
JW09	YJ0100086	Jack, Headphone
0918	289212002	Insulator
		<b>PUSH-SWITCH ASS'Y BOARD-PS01</b>
PS01	YD2904005 ZZ2904005	P.W. Board, Pushswitch (Print Only) P.W. Board Assembly
		<b>PS01-RESISTORS</b>
RS01	RT0539214	3.9KΩ ± 5%, ¼W
RS02	RT0539214	3.9KΩ ± 5%, ¼W
RS03	RT0539214	3.9KΩ ± 5%, ¼W
RS04	RT0539214	3.9KΩ ± 5%, ¼W
RS05	RT0522314	22KΩ ± 5%, ¼W
RS06	RT0522314	22KΩ ± 5%, ¼W
RS07	RT0522314	22KΩ ± 5%, ¼W
RS08	RT0522314	22KΩ ± 5%, ¼W
RS09	RT0512314	12KΩ ± 5%, ¼W
RS10	RT0512314	12KΩ ± 5%, ¼W
RS11	RT0512314	12KΩ ± 5%, ¼W
RS12	RT0512314	12KΩ ± 5%, ¼W
RS13	RT0512314	12KΩ ± 5%, ¼W
RS14	RT0512314	12KΩ ± 5%, ¼W
RS15	RT0512314	12KΩ ± 5%, ¼W
RS16	RT0512314	12KΩ ± 5%, ¼W
RS17	RT0547414	470KΩ ± 5%, ¼W
RS18	RT0547414	470KΩ ± 5%, ¼W
RS19	RT0547414	470KΩ ± 5%, ¼W
RS20	RT0547414	470KΩ ± 5%, ¼W
RS21	RT0522514	2.2MΩ ± 5%, ¼W
RS22	RT0522514	2.2MΩ ± 5%, ¼W
RS23	RT0522514	2.2MΩ ± 5%, ¼W
RS24	RT0522514	2.2MΩ ± 5%, ¼W
		<b>PS01-CAPACITORS</b>
CS01	DK1668101	Ceramic, 680PF ± 10%
CS02	DK1668101	Ceramic, 680PF ± 10%
CS03	DK1668101	Ceramic, 680PF ± 10%
CS04	DK1668101	Ceramic, 680PF ± 10%
CS05	EM1040251	Electroly, 0.1μF ± 20%
CS06	EM1040251	Electroly, 0.1μF ± 20%
CS07	EM1040251	Electroly, 0.1μF ± 20%
CS08	EM1040251	Electroly, 0.1μF ± 20%
CS09	DF1522201	Film, 2200PF ± 5%
CS10	DF1522201	Film, 2200PF ± 5%
CS11	DF1522201	Film, 2200PF ± 5%
CS12	DF1522201	Film, 2200PF ± 5%
CS13	DF1510201	Film, 1000PF ± 5%
CS14	DF1510201	Film, 1000PF ± 5%
CS15	DF1510201	Film, 1000PF ± 5%



REF. DESIG.	PART NO.	DESCRIPTION
CS16	DF1510201	Film, 1000PF ± 5%
CS17	DF1547201	Film, 4700PF ± 5%
CS18	DF1547201	Film, 4700PF ± 5%
CS19	DF1547201	Film, 4700PF ± 5%
CS20	DF1547201	Film, 4700PF ± 5%
CS21	DF1547201	Film, 4700PF ± 5%
CS22	DF1547201	Film, 4700PF ± 5%
CS23	DF1547201	Film, 4700PF ± 5%
CS24	DF1547201	Film, 4700PF ± 5%
CS25	DF1733305	Film, 0.033μF ± 20%, 50V
CS26	DF1733305	Film, 0.033μF ± 20%, 50V
<b>PS01-MISCELLANEOUS</b>		
SS01	SP0406004	Pushswitch
JS01	YP1000120	Plug
JS06		
0910	290410903	Shield
R014	RM0503056	Variable Resist., 50KΩ(B), Dimension
M001	IM1102416	DC Meter, Dolby Level
C004	EA4740509	Electroly Cap., 0.47μF, 50V
R029	RT0539214	Resistor, 3.9KΩ ± 5%, ½W
<b>METER ILLUMINATION BOARD-PX01</b>		
PX01	YD2904007	P.W. Board, Meter Illumination (Print Only)
	ZZ2904007	P.W. Board Assembly
<b>PX01-MISCELLANEOUS</b>		
MX01	IN1008036	Lamp, 8V, 0.2A
RX01	RC1004712	Resistor, 47Ω ± 10%, ½W
JX01	YP1000113	Plug
JX02	YP1000113	Plug
JX03	YJ0800017	Socket
JX04	YJ0800017	Socket
<b>GENERAL MISCELLANEOUS</b>		
1034	289210908	Shield
1035	203912001	Insulator
0513	51100308S	B.H.M. Screw x 16
0514	53110303E	Hexagon Nut x 16
0516	51100306S	B.H.M. Screw x 8
0522	54050400R	T.L. Washer OR
0532	145525903	Bush
0533	145525903	Bush
0535	284906701	Cap, For CANADA
0616	51470306A	B.H.M. Screw S x 3
0619	53228059E	Nut x 3
0620	51100304S	B.H.M. Screw x 2
0622	51100304S	B.H.M. Screw x 2
0631	51100314S	B.H.M. Screw x 2
0632	53110303E	Hexagon Nut x 2
J001	YT0304003	Terminal, 4P, AM/FM Ant.
J002	YT0201006	Terminal, 1P, Quadradial
J003	YT0204003	Terminal, 4P, Phono, Aux
J004	YT0208002	Terminal, 8P, Tape 1, 2
J005	YT0202007	Terminal, 2P, Aux (Rear)
J006	YT0208002	Terminal, 8P, Tape 1, 2
J007	YT0204003	Terminal, 4P, Pre Out Main In
J008	YT0204003	Terminal, 4P, Pre Out Main In
J013	YT0101003	Terminal, Ground

REF. DESIG.	PART NO.	DESCRIPTION
J015	YP1000097	Plug, Pre Out ↔ Main In
J016	YP1000097	Plug, Pre Out ↔ Main In
J017	YP1000097	Plug, Pre Out ↔ Main In
J018	YP1000097	Plug, Pre Out ↔ Main In
J029	YJ0800012	Plug
J044	YL0103003	Terminal, 3P
W001	YC0240010	AC Cord, (UL)
S006	SS0402022	Slide Switch, Remote Control
F001	FS1080002	Fuse, 8A, For CANADA
F001	FS1080004	Fuse, 8A (UL)
F003	FS2080090	Fuse, 8A, For CANADA
F002	FS1030006	Fuse, 8A, For CANADA
R012	RA0203007	Trimming Resist., 20KΩ(B), FM Muting
R020	RK0103023	Variable Resist., 10KΩ(B), V, Center
R021	RK0103023	Variable Resist., 10KΩ(B), H, Center
R022	RA0503018	Trimming, 50KΩ(B), Bright
R023	RK0204006	Trimming, 200KΩ(B), Focus
1451	288615402	Knob, Scope VR x 2
J009	YT0304005	Terminal, 4P, Spkr (Main)
J010	YT0304005	Terminal, 4P, Spkr (Main)
J011	YT0304005	Terminal, 4P, Spkr (Remote)
J012	YT0304005	Terminal, 4P, Spkr (Remote)
0517	51100305S	B.H.M. Screw x 6
0518	289016004	Bracket
0519	289016005	Bracket x 2
0520	289012002	Insulator
1751	138200503	Clamper
<b>SPEAKER PROTECTOR CIRCUIT BOARD-PN01</b>		
PN01	YD2890006	P.W. Board, SP Protector (Print Only)
	ZZ2904106	P.W. Board Assembly
<b>PN01-MISCELLANEOUS</b>		
JN01	YP1000113	Plug
JN13		
RN01	GJ0533102	Resistor, 330Ω ± 5%, 2W
RN02	GJ0533102	Resistor, 330Ω ± 5%, 2W
RN03	GJ0533102	Resistor, 330Ω ± 5%, 2W
RN04	GJ0533102	Resistor, 330Ω ± 5%, 2W
RN05	GU1056212	Resistor, 5.6KΩ ± 10%, ½W
RN06	GU1056212	Resistor, 5.6KΩ ± 10%, ½W
RN07	GU1056212	Resistor, 5.6KΩ ± 10%, ½W
RN08	GU1056212	Resistor, 5.6KΩ ± 10%, ½W
HN01	HD2000321	Diode, 1S2471 (Black)
HN02	HD2000321	Diode, 1S2471 (Black)
LN01	LY4048001	Relay, 48V DC, 4P
LN02	LY4048001	Relay, 48V DC, 4P
J032	YJ1100012	Jack, Remote Control
0626	289227103	Holder
0627	138200503	Clamper
0628	51380308P	R.H. Tap Screw x 2

REF. DESIG.	PART NO.	DESCRIPTION
PU01	YD2892012 ZZ2904112	<b>FM DE-EMPHASIS CIRC. BOARD-PU01</b> P.W. Board, FM De-Emphasis (Print Only) P.W. Board Assembly
CU01	DF6520201	<b>PU01-MISCELLANEOUS</b> Film Cap., 2000PF ± 5%
CU02	DF6520201	Film Cap., 2000PF ± 5%
SU01	SS0202017	Slide Switch, 25μs ↔ 75μs
JU01 ? JU10	YP1000113	Plug
L001	LF1120023	<b>GENERAL MISCELLANEOUS</b> Ant. Coil, AM, Ferrite Rod
0602	257816052	Bracket K
0607	281927103	Holder
0609	51100310S	B.H.M. Screw x 2
0610	53110301E	Hexagon Nut x 2
0612	51100308S	B.H.M. Screw x 2
0613	53110301E	Hexagon Nut x 2
C006	DK1710301	Ceramic Cap., 0.01μF ± 20%
2651	62031650W	Lug
R024	RC1022512	Resistor, 2.2MΩ ± 10%, ¼W
2652	62031650W	Lug
LU01	LB3007526	Balun Coil, 300Ω ↔ 75Ω
1434	62041760W	Lug
0911	289210701	Sheet
1710	290430201	Dial
S001	SR1506004	Rotary Switch, Selector
R006	RT0556314	Resistor, 56KΩ ± 5%, ¼W
R007	RT0515314	Resistor, 15KΩ ± 5%, ¼W
S002	SR1305002	Rotary Switch, Mode
R005	RT0547014	Resistor, 47Ω ± 5%, ¼W
S003	SR2405001	Rotary Switch, Dolby
R001	RT0510214	Resistor, 1KΩ ± 5%, ¼W
R003	RT0510214	Resistor, 1KΩ ± 5%, ¼W
S004	SR1403001	Rotary Switch, Tape Monitor
R002	RT0510214	Resistor, 1KΩ ± 5%, ¼W
R004	RT0510214	Resistor, 1KΩ ± 5%, ¼W
S005	SR0602010	Rotary Switch, Amp. Mode
J003	YJ0600020	Jack, 11P, Power Supply
PC01	YD2892011 ZZ2904111	<b>FM CALIBRATION CIRC. BOARD-PC01</b> P.W. Board, FM Cal. (Print Only) P.W. Board Assembly
RC01	RT0582314	<b>PC01-MISCELLANEOUS</b> Resistor, 82KΩ ± 5%, ¼W
RC02	RT0582314	Resistor, 82KΩ ± 5%, ¼W
RC03	RT0510314	Resistor, 10KΩ ± 5%, ¼W
RC04	RT0510314	Resistor, 10KΩ ± 5%, ¼W
RC05	RK0203030	Variable Resist, 20KΩ (B)
RC06	RK0203030	Variable Resist, 20KΩ (B)
JC01 ? JC05	YP1000120	Plug

REF. DESIG.	PART NO.	DESCRIPTION
1212	290405302	<b>GENERAL MISCELLANEOUS</b> Cover
1214	290430202	Dial
1216	290400501	Clamper
1220	51060204E	P.H.M. Screw
M002	IN1005003	Lamp, 5V, 6mA, Scope Scale Illumi.
H011	VB0023501	Picture Tube, 3" Scope
0921	51100304S	B.H.M. Screw x 2
0928	290400503	Clamper
0929	54020301S	Flat Washer P
0930	51100308S	B.H.M. Screw
1203	290410901	Shield
1205	290405601	Buffer
1428	290405602	Buffer
H009	HD2001008	Diode, 1S2724S
H010	HD2001108	Diode, 1S2724R
C007	DF1710452	Film, 0.1μF, 400V
C010	DF1710452	Film, 0.1μF, 400V
J027	YJ0500017	Socket, For Rectifier
J028	YJ0500017	Socket, For Rectifier
1414	290426701	Heat-Sink
1415	51380306T	B.H.M. Screw x 5
1416	51100310E	B.H.M. Screw x 4
1417	54050300R	T.L. Washer OR x 5
1418	121000501	Clamper
J039	YL0107001	Terminal, 7P
R011	GJ0512103	Resistor, 120Ω ± 5%, 3W
R027	RT0568314	Resistor, 68KΩ ± 5%, ¼W
C009	DF1747401	Film Cap., 0.47μF ± 20%, 50V
J038	YL0105001	Terminal, 5P
R028	RT0510414	Resistor, 100KΩ ± 5%, ¼W
C005	DK1710301	Ceramic Cap., 0.01μF ± 20%
L002	LC1332002	Choke Coil, 3.3μH
J035	YJ0700009	Jack, 19P, Dolby
J014	YJ0700006	Jack, SQ Decoder
1405	289210404	Retainer
1406	285110450	Retainer
1410	51100310S	B.H.M. Screw x 2
1411	59030805P	Fiber Washer x 2
1412	51100305S	B.H.M. Screw x 2
R013	RA0503014	Trimming Resist, 50KΩ (B) FM Muting
1425	289216012	Bracket
1919	62031650W	Lug
0634	289210907	Shield
0635	281912004	Insulator
1504	290410902	Shield
1533	290412004	Insulator
1514	290416004	Bracket, For CANADA
1516	51100308S	P.H.M. Screw, For CANADA
J045	YJ0800018	Socket, For CANADA
PP01	YD2904008 ZZ2904008	<b>FUSES BOARD-PP01</b> P.W. Board, Fuse (Print Only) P.W. Board Assembly
JP01	YJ0700010	<b>PP01-MISCELLANEOUS</b> Socket

REF. DESIG.	PART NO.	DESCRIPTION
JP02 }	YP1000099	Plug
JP09		
JP10 }	YJ0800017	Socket
JP21		
FP01 }	FS1005009	Fuse, 0.5A
FP04		
FP05	FS1015005	Fuse, 1.5A
FP06	FS1015005	Fuse, 1.5A
<b>GENERAL MISCELLANEOUS</b>		
1924	290416005	Bracket
1927	51100304S	B.H.M. Screw x 2
1503	138200503	Clamper x 8
2023	138200503	Clamper
0429	62031650W	Lug
0432	62261240W	Lug
0320	282186102	Label, Fuse Caution, For CANADA
0411	275905701	Leg x 4
0412	51490410S	B.H.M. Screw FS
0428	51570308B	P.H. Tapt Screw
0430	54050300R	T.L. Washer OR
0431	53110303E	Hexagon Nut
0433	54052600R	T.L. Washer OR
7051	53228059E	Nut x 2
7052	51100304S	B.H.M. Screw
0924	288810101	Support
0925	51100305S	B.H.M. Screw
1003	290416007	Bracket
1004	290416008	Bracket
1005	51100406A	B.H.M. Screw x 6
1018	289226251	Pulley K
1023	51100305A	B.H.M. Screw x 2
1207	290410101	Support x 2
1209	290435701	Rad
1218	51100306S	B.H.M. Screw x 2
1222	54050400R	T.L. Washer OR x 2
1224	289216011	Bracket
1225	51570406B	P.H. Tapt Screw x 2
1229	289210903	Shield
1230	51570305B	P.H. Tapt Screw x 2
1231	51570305B	P.H. Tapt Screw x 2
1232	289210906	Shield
1233	289210106	Support x 2
1234	54040302N	Spring Washer x 2
1303	290410550	Chassis K
1313	288810102	Support x 4
1314	285110101	Support x 4
1315	289225901	Bush x 2
1317	51100304S	B.H.M. Screw x 2
1318	51100306S	B.H.M. Screw x 2
1319	51100306S	B.H.M. Screw x 2
1320	51100306S	B.H.M. Screw x 3
1321	51100306S	B.H.M. Screw x 4
1322	51100306S	B.H.M. Screw x 2

REF. DESIG.	PART NO.	DESCRIPTION
1323	51100306S	B.H.M. Screw x 3
1324	51100306S	B.H.M. Screw x 8
1325	51100306S	B.H.M. Screw x 2
1326	51570406B	P.H. Tapt Screw x 4
1327	51570306B	P.H. Tapt Screw x 2
1328	51570306B	P.H. Tapt Screw x 3
1329	51570306B	P.H. Tapt Screw x 14
1330	51570306B	P.H. Tapt Screw x 4
1332	51570306B	P.H. Tapt Screw x 8
1334	51570305B	P.H. Tapt Screw x 2
1335	51570305B	P.H. Tapt Screw x 2
1402	289210901	Shield
1403	285610102	Support x 2
1404	281810107	Support x 3
1409	51100304S	B.H.M. Screw x 5
1419	59030805P	Fiber Washer x 2
1420	54040302N	Spring Washer x 2
1421	288910904	Shield
1423	51570408B	P.H. Tapt Screw
1424	289210902	Shield
1429	282600502	Clamper
1430	51570306B	P.H. Tapt Screw
1435	54050400R	T.L. Washer OR
1501	51570305B	P.H.M. Screw x 2
1505	51102605E	B.H.M. Screw x 2
1506	281805601	Buffer x 2
1507	54050300R	T.L. Washer OR x 11
1508	288700501	Clamper x 6
1510	138200503	Clamper
1511	51570305B	P.H. Tapt Screw x 3
1512	51570305B	P.H. Tapt Screw x 6
1513	51570305B	P.H. Tapt Screw x 6
1519	51570308B	P.H. Tapt Screw x 2
1528	51100614A	B.H.M. Screw x 4
1529	53110601A	Hexagon Nut x 4
1530	54020801A	Flat Washer P x 4
1531	54040601A	Spring Washer x 4
1532	54020601A	Flat Washer P x 4
1534	282110103	Support x 2
1535	51102605A	B.H.M. Screw x 2
1918	51570305B	P.H. Tapt Screw
1921	290412003	Insulator
1925	51100304S	B.H.M. Screw
1926	54020301S	Flat Washer
1928	51100305S	B.H.M. Screw
0802	288610105	Support
0803	289210108	Support
0804	59030810P	Fiber WS x 2
R025	GJ0522201	Resistor, 2.2K $\Omega$ $\pm$ 5%, 1W
R026	GJ0522201	Resistor, 2.2K $\Omega$ $\pm$ 5%, 1W
C002	EC2090501	Electroly Cap., 20000 $\mu$ F, 50V
C003	EC2090501	Electroly Cap., 20000 $\mu$ F, 50V
L003	TS6330203	Power Transf.
0121	289206451	Case K
0202	289225701	Lid
0203	257711803	Spacer x 2
0204	289205602	Buffer x 3
0205	288611801	Spacer x 4
0217	290415401	Knob, Volume x 3
0218	290415402	Knob, Pushswitch x 12
0219	290415404	Knob, Power Switch

REF. DESIG.	PART NO.	DESCRIPTION
0220	290415403	Knob, Dolby x 4
0221	281815403	Knob, Dolby x 6
0232	288615402	Knob, B.T.L.
0302	290426501	Indicator, Model No.
0303	290426502	Indicator, Model No., For CANADA
0309	51100305S	B.H.M. Screw x 2
0311	257886101	Label, UL Caution
0312	257886102	Label, Do not remove cover.
0313	257886103	Label, See marking on bottom.
0314	250626506	Indicator, Do not use as handle.
0334	288686101	Label, Marantz On Power Transf.
0335	288686102	Label, Dolby
0402	52017039J	Bolt, Decord x 4 - Front Panel
0404	51100406S	B.H.M. Screw x 11
0406	51480406S	B.H.M. Screw F x 4
0418	51122605S	T.H.M. Screw x 4
0420	289205502	Collar x 2
0421	541140191	Washer x 2
0425	51340308P	F.H. Tap Screw
0816	56382540G	Eyelet
0922	290405303	Cover, Scope P.W. Board
0923	51100305S	B.H.M. Screw x 3
1226	289200301	Punched Plate x 2
1227	51100304S	B.H.M. Screw x 4
1228	51570305B	P.H. Tapt Screw x 4
1235	54020301E	Flat Washer P x 4
1316	51100305S	B.H.M. Screw x 2
1333	51570306B	P.H. Tapt Screw x 3
1413	203912001	Insulator
1422	288910905	Shield
1602	285011202	Shaft
1603	54040402N	Spring Washer
1702	289226901	Protector
1704	289226902	Protector
1708	281912004	Insulator
1714	51570305B	P.H. Tapt Screw x 2
1719	51100304S	B.H.M. Screw x 2
1721	290426901	Protector
1905	290412002	Insulator
1908	281912004	Insulator
1914	289205302	Cover, Dolby P.W. Board
1911	51100304S	B.H.M. Screw x 4
2006	289010903	Shield
2108	51100305S	B.H.M. Screw x 2
2124	289205601	Buffer x 4
2202	290485101	Instructions, For Unit
2209	290485601	Schematic Diagram
2211	290485603	Schematic Diagram, For CANADA
2216	281885104	Instructions
2217	281885108	Instructions, For Accessories
2221	257785450	Guarantee Card K
2304	290480103	Packing Case, . . . Inner
2305	290480104	Packing Case, . . . Outer
2307	289280301	Partitioner, Top Cushion
2308	289280302	Partitioner, Bottom Cushion
2312	901534543	Polyethylen Bag, For Unit

REF. DESIG.	PART NO.	DESCRIPTION
2314	901302501	Polyethylen Bag x 2, For Accessories
2317	102980401	Sleeve, For AC Cord
2319	273182101	Silicagel x 2
2320	281905601	Buffer
2322	285125703	Lid, SQ
2323	285386101	Label, SQ Caution
2324	51216059E	Screw x 4
2331	ZA0200007	Ext. Antenna, FM

## TECHNICAL SPECIFICATIONS

### PREAMPLIFIER SECTION

Dynamic Range	Phono input: 96dB above 1.5 $\mu$ V equivalent noise input
Note:	Dynamic Range is the ratio in dB of phono overload (100mV) to equivalent input noise (1.5 $\mu$ V).
Input Sensitivity and Impedance	Phono: 1.8mV, 47 Kohms High Level: 180mV, 100 Kohms
Pre-out Output Level	1V
Pre-Out Output Impedance	900 ohms
Phono Frequency Response	30Hz to 15KHz $\pm$ 1dB (RIAA)
Noise-Aux	-80dB
Tone Controls	Treble: $\pm$ 10dB at 15KHz Bass: $\pm$ 10dB at 50Hz Mid-Range: $\pm$ 6dB at 700Hz
Filters	Hi Filter: 9KHz, 12dB per octave Low Filter: 50Hz, 12dB per octave
Loudness Compensation	7dB at 100Hz 4dB at 10KHz

### AMPLIFIER SECTION

Headphones Output	.047V into 8 ohms at rated distortion
Input Sensitivity for MAIN in Front/Rear	1V
Power Output	200 Watts into 8 ohms (50W/channel x 4) 250 Watts into 8 ohms (125W/channel x 2)
Total Harmonic Distortion	At or below rated power, 20Hz to 20KHz Less than 0.15%, typically 0.05% including preamplifier (AUX)
IHF Power Bandwidth	8Hz-70KHz
Frequency Response	$\pm$ 2dB, 5Hz to 70KHz $\pm$ 1dB, 10Hz to 30KHz
Damping Factor	2-channel Mode: 40 at 20Hz 4-channel Mode: 50 at 20Hz

### FM SECTION

Quieting Slope	1.8 $\mu$ V for 30dB, 5 $\mu$ V for 55dB 10 $\mu$ V for 60dB, 50 $\mu$ V for 70dB
Ultimate Quieting	50 $\mu$ V for 70dB
Selectivity	Alternate channel, better than 75dB
Capture Ratio	1.5dB
Muting Threshold	Muting threshold variable from 8 $\mu$ V to 35 $\mu$ V
Stereo Separation	42dB at 1KHz, 27dB at 15KHz
Total Harmonic Distortion	Stereo: Less than 0.3% Mono: Less than 0.2%
Frequency Response	$\pm$ 1dB, 30Hz to 15KHz
Total Spurious Rejection	Better than 95dB
Image Rejection	Better than 90dB
AM Suppression	Better than 60dB
IF Rejection	Better than 100dB
Antenna Impedance	300 ohm Balanced, 75 ohm unbalanced
Quadradial Output	300mV, 15 Kohms for $\pm$ 75KHz Dev.

### AM SECTION

AM Sensitivity	20 $\mu$ V
----------------	------------

Selectivity ..... Adjacent channel, 1000KHz, better than 30dB  
AM Bandwidth ..... (-6dB) 7KHz  
Image Rejection ..... 1400KHz, better than 70dB

**GENERAL**

Power Requirements ..... 120V AC, 50 to 60Hz  
Power Consumption – at rated power output, all channels ..... 690 Watts  
– idling (no signal) ..... 65 Watts  
Dimensions – Panel Width ..... 19-19/64" – 490mm  
– Panel Height ..... 5-3/4" – 146mm  
– Depth ..... 15-13/64" – 386mm  
Weight – Unit alone ..... 51.6 lbs  
– Packed for Shipment ..... 62.7 lbs

\* These specifications and exterior designs may be changed for improvement without advance notice.

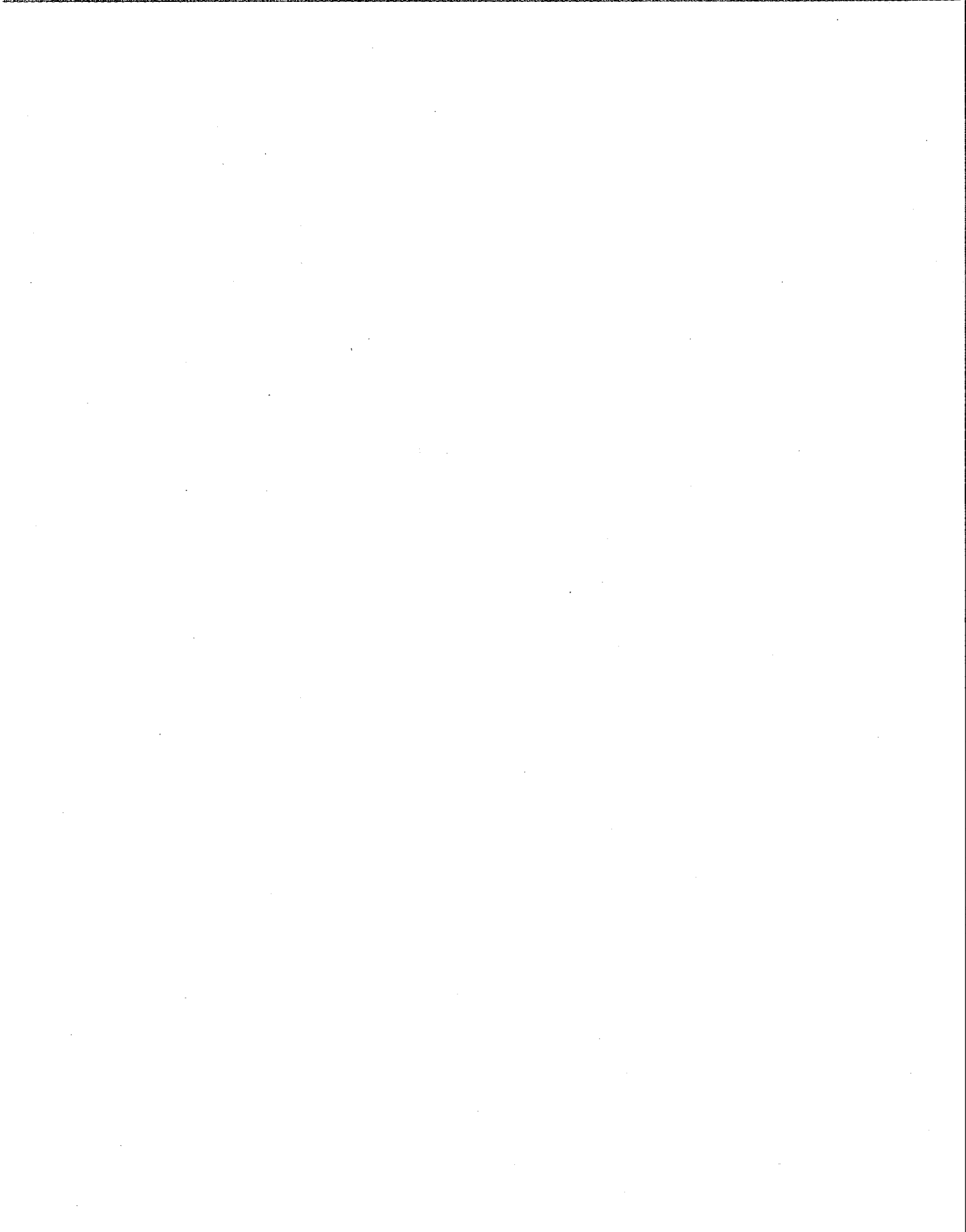
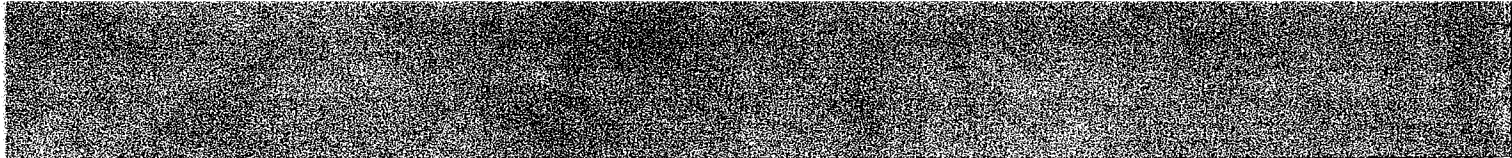



**marantz.**

**MARANTZ CO., INC. • P.O. BOX 577 • CHATSWORTH, CALIFORNIA • 91311**



A WHOLLY-OWNED SUBSIDIARY OF SUPERSCOPE INC., CHATSWORTH, CALIFORNIA • 91311

SQ is a trademark of CBS INC.

Noise reduction circuit under license from Dolby Laboratories, Inc.

"DOLBY" and the Double-D symbol are trademarks of Dolby Laboratories, Inc.